

**AIRBUS**

HELICOPTERS  
Services

# Standard Upgrades

January 2023

H175  
EC175 & H175



**AIRBUS**

# Introduction

## Dear Customers,

In the aim of continuously improving our services, Airbus Helicopters is pleased to present you this new pdf version for the catalogue of Standard Upgrades.

Airbus Helicopters proposes tailored solutions to increase the helicopter's overall performance and mission effectiveness with role change capabilities, contributing to harmonized fleet, product improvement and maintenance cost reduction.

A wide range of solutions, from optional equipment up to mid- life upgrades, is available to bring aircraft to the latest version. These modifications, perfectly adapted to customers' aircraft configuration, are benefitting from innovations and advanced technology defined by Airbus Helicopters' experienced design office teams.

These upgrades give extended life to customer aircraft while covering obsolescence, with the added assurance of proven, certified and safe modifications developed by the Type Certificate holder as well as Supplemental Type Certificate holders.

Airbus Helicopters proposes a large range of service bulletins (SB) and supplemental type certificates (STC) solutions available through its worldwide network, certified in accordance with international authorities (FAA, EASA...) and local requirements.

The standardization of such services (including kits preparation and certification) allows shorter lead times and greater competitiveness.

The complete and growing range of SB/STC standard upgrades is available on our AirbusWorld customer portal, which allows e-ordering of the associated kits. Together with a search engine, several filtering criteria will allow you to find the adequate available solution to answer your need, such as Equipment Categories, Aircraft type, ATA chapter as well as Airworthiness certifications.

Airbus Helicopters offers also customers Customized upgrades solution, developed according to the as-delivered configuration of their helicopter. This service is also available from the standard upgrades catalogue on AirbusWorld through a request for quotation available online.

With the comprehensive Turnkey solution, Airbus Helicopters both designs and installs upgrades on customer's aircraft. This work can be performed either within the Airbus Helicopters network or at customer facilities.

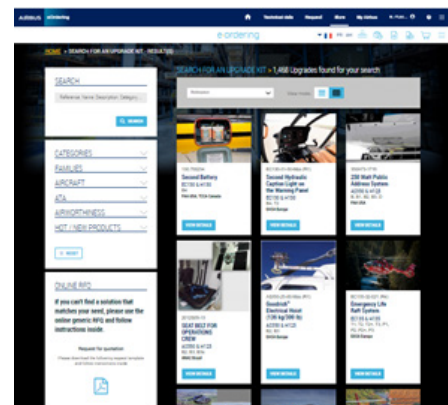



# WHEREVER YOU OPERATE... WE SUPPORT YOU

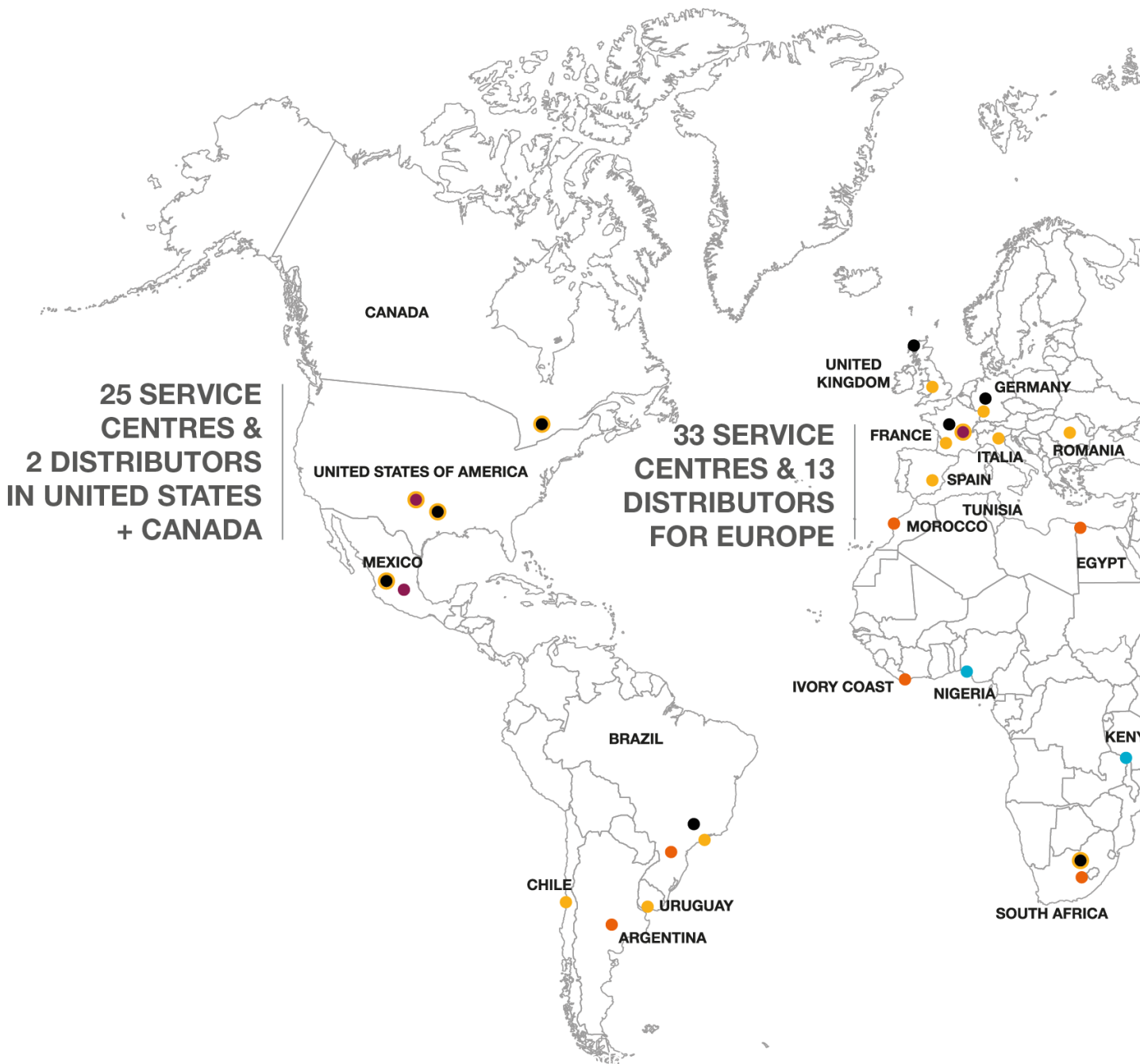

**OUR GLOBAL NETWORK SPANS MORE THAN 150 COUNTRIES WITH AN EXTENSIVE APPROVED MAINTENANCE NETWORK LOCATED IN CLOSE PROXIMITY TO CUSTOMER FACILITIES:**

- 30 main sites, customer centres and affiliated sites
- 38 helicopters and/or support & services distributors.
- 92 service centres.
- 10 logistics hubs and local inventories, as well as multiple local stock warehouses.
- 4 technical support hubs.



Find your service centre with our Heli Presence App on your mobile devices or through our Airbus Helicopters web site

<https://www.airbus.com/en/products-services/helicopters/>



# User Guide

Search efficiently in Airbus Helicopters catalogues by product categories and sub-categories.

Select an aircraft family catalogue...



## Aircraft families

- Colibri
- Ecureuil family
- H135 family
- H145 family
- Dauphin family
- H175
- Super Puma family

Please note that regarding the version of the catalogue, all the families are not necessarily represented

...then search by product category

## Product categories



Aircraft improvement



Airframe options



Cockpit & avionics options



Interior options



Maintenance improvement



Mission & external equipment



Obsolescence management



Operational protection



Power plant related options



Product improvement



Safety



Please note that regarding the version of the catalogue, all the segments are not necessarily represented.

# How to read the product page

Type of Upgrade (SB or STC)  
Back to the Table of contents

Airframe options  
AS350 & H125

Product category  
Aircraft applicability

## Windshield Wipers for pilot and co-pilot (opt)

Reference: AS350-30-40-Max (X0)  
Applicable to version(s): 82, 83, 83e

**Installation of windshield wiper for pilot and co-pilot.**

This Service Bulletin consists in :  
Installing the Removable Part (RP) of the pilot and copilot windshield wipers.  
Carrying out the adjustments and tests of the windshield wiper installation.

**BENEFITS**

- Better visibility in rainy weather conditions.

WEIGHT	MOMENT	DOWNTIME	LEAD TIME	PRICE RANGE	ONLINE CAT.
+2.5 kg per windshield wiper installation	+1.265 m.kg per windshield wiper installation	1 Day(s) or 2 Day(s) depending on aircraft configuration	22 Week(s)	5381 - 6440 EUR (e.c. 2020)	eOrdering

**INSTALLATION TIME**

QUALIFICATION	INSTALLATION DURATION
Airframe, Electrical	2 to 4 Hour(s) depending on aircraft configuration
Aircraft Maintenance Engineer	3 to 6 Hour(s) depending on aircraft configuration

**PRE-POST REQUISITE / EFFECTIVITY**

This service bulletin is applicable on aircraft already equipped with :  
MOD 074280 (Multi-unit installation) and not equipped with :  
MOD 074292 (Installation of windshield wiper optional equipment by Multi-Unit) thru drawing 350A8280S2.07 or 350A8280S2.08  
MOD AL4295 (Change in windshield wiper relay both) (the following MOD also impact the applicability of the SB (will be selected in the CONFIGURATION ASSISTANT)  
MOD 073439 (Ecoreull canopy re-design)

**CERTIFICATION ORGANIZATION(S)**  
EASA Europe

Commercial interface availability in the online catalogue on Customer's portal AirbusWorld/Ordering:  
eOrdering with configuration assistant or eRFQ

Bilateral agreement between Certification Authorities are not considered in this Upgrades catalogue.  
SB are indicated EASA approved : other certifications already exist on case by case basis, to be checked with your own local Authority.  
For STC, complementary certifications can be requested, to be checked with your usual AH commercial interface.

Please visit the Upgrades catalogue on AirbusWorld/Ordering for online eOrdering and eRFQ.  
<https://airbusworld.helicopters.airbus.com/>

Version of the catalogue  
Contact information

# What do these icons mean ?

## Type of Upgrades



Service Bulletin  
Or  
Supplemental Type  
Certificate

## Weight



Delta weight of the A/C  
due to Upgrade  
installation

## Moment



Longitudinal moment  
value

## Downtime



Average value based on  
qualified technicians with  
appropriate tooling





## Lead time



Average value based on  
usual stock

# Table of contents

## H175

 <b>Airframe options</b>		HUMS : Definition of vibration thresholds on Maintenance Ground Station (MGS)	36
doors related		Improvement of maintenance during installation of the hoist	37
Addition of a handle on cargo doors	11	Improvement of the cargo doors holding system	38
		Improvement of the Nose landing gear with new frame assembly	39
		Landing Gear Equipment TITFLEX Pipe Replacement	40
		Multifunction Displays - Aircraft Management Computer	41
		New design of seals in bottom structure fairings	42
		New Inertia Switch (CVFDR)	43
		Relocation of HEELS Power Supply Units	44
		Replacement of the access hatches of the last engine firewall	45
		Replacement of the label on the bearing support assembly of the tail drive line	46
		Replacement of the tail fairing fasteners and adaptation of the fairings	47
 <b>Cockpit &amp; avionics options</b>			
cockpit panel & console options			
Modification of the mission selector	13		
 <b>Interior options</b>			
cabin accessories			
Installation of 220V cabin converter	16		
other options			
Anti-skid adhesives in the cockpit	15		
 <b>Maintenance improvement</b>			
Ground station retrofit - MGS V1.7	19		
 <b>Obsolescence management</b>			
Back-up battery pack modification due to battery obsolescence	21		
Replacement of cockpit and cabin fire extinguishers	22		
 <b>Power plant related options</b>			
fuel filters & control			
Non-return valve modification	25		
 <b>Product improvement</b>			
Addition of a gutter with drains in the nose avionics bay	27		
AMC from STEP 2 to STEP 2R	28		
Cable hoist protection	29		
Creation of a new bearing hanger assembly	30		
Drainage of the low point under TGB/IGB	31		
Firewall lower vertical angles replacement	32		
Firewall Tunnel Reinforcement	33		
Health and Usage Monitoring System (HUMS) - HMS Configuration file	34		
HUMS - Definition of the vibration thresholds on the maintenance ground station (in VIP configuration)	35		
		 <b>Safety</b>	
		extreme weather	
		Protection against ice impacts on horizontal stabilizer	50
		Winter kit installation	53
		other options	
		Hand Fire Extinguisher	49
		Replacement of halon-free hand fire-extinguisher on the lower rear panel of the cabin	51
		Replacement of hand fire extinguisher without Halon in the cabin (17 or 18 pax)	52
		<b>Standard Conditions Of Sale</b>	54







H175

---

EC175 & H175



# AIRFRAME OPTIONS



# Addition of a handle on cargo doors

Reference: EC175-52-001 (R0)

Applicable to version(s): B

**The purpose of this Service Bulletin is to install a handle inside the cargo doors.**

This service bulletin consist in :

- Implement suitable access means
- Remove all furnishings and equipment as required for access to work zones
- Install handle

SB from Airbus Helicopters France (AHF)



## > BENEFITS

- Improve the closing of the cargo door.

WEIGHT	MOMENT	DOWNTIME	LEAD TIME	PRICE RANGE	ONLINE CAT.
Negligible	Negligible	12 Hour(s)	Depending on Spare Parts needed	Ref to detailed price online.	eOrdering

## > PRE-POST REQUISITE / EFFECTIVITY

This service bulletin is applicable on aircraft not equipped with :

- 99A03705-00-M-ECP/00 : Addition of a handle on cargo doors

## > CERTIFICATION ORGANIZATION(S)

EASA Europe

# COCKPIT & AVIONICS OPTIONS





# Modification of the mission selector

Reference: EC175-25-025 (R0)

Applicable to version(s): B

**The purpose of this Service Bulletin is to replace the lighting plate of the mission selector unit (8MR) to make visible the position of the (HOIST/OFF/SLING) button at night and in night vision mode.**

This Service Bulletin consists in:

- Replacing the lighting plate of the mission selector unit "8MR"
- Reidentifying the unit

SB from Airbus Helicopters France (AHF)

PRE MOD and POST MOD components are not interchangeable.

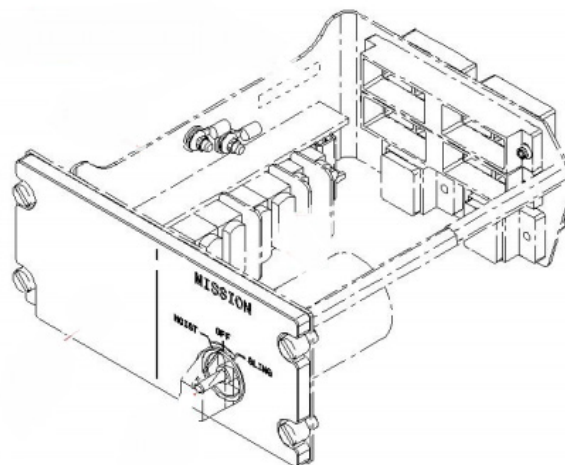

## > BENEFITS

- Make visible the position of the (HOIST/OFF/SLING) button at night and in night vision mode

WEIGHT	MOMENT	DOWN TIME	LEAD TIME	PRICE RANGE	ONLINE CAT.
Negligible	Negligible	2 Hour(s)	On request	On request	eOrdering

## > INSTALLATION TIME

QUALIFICATION	INSTALLATION DURATION
Avionics	2 Hour(s)

## > PRE-POST REQUISITE / EFFECTIVITY

This service bulletin is applicable on aircraft already equipped with :

- MOD 00A00122-00-M-ECP (External loads jettison system and mission selector definition)

and not equipped with:

- MOD 00A05296-00-M-ECP/01 (P904-Elec\_Mission Selector Modification)

## > CERTIFICATION ORGANIZATION(S)

EASA Europe

# INTERIOR OPTIONS



# Anti-skid adhesives in the cockpit

Reference: EC175-53-004 (R0)

Applicable to version(s): B

**The purpose of this Service Bulletin is to install anti-skid adhesives on the cockpit floor and/or the cockpit door sills.**

This Service Bulletin consists of installing, as required, anti-skid adhesives :

- On the cockpit door sills (modification 99A03960-00-M-ECP)
- On the cockpit floor (modification 99R01064-00-M-ECP)

SB from Airbus Helicopters France (AHF)



## > BENEFITS

- Avoid slippery floor on the cockpit/or the cockpit door sills.

WEIGHT	MOMENT	DOWN TIME	LEAD TIME	PRICE RANGE	ONLINE CAT.
+ 0.049 kg to 1,980 kg depending on aircraft configuration.	+ 0.206 m.kg to 0,806 m.kg depending on aircraft configuration.	12 Hour(s)	8 Week(s)	180 - 1153 EUR (e.c. 2023)	eOrdering

## > PRE-POST REQUISITE / EFFECTIVITY

This service bulletin is applicable on aircraft not equipped with :

- MODs 99A03960-00-M-ECP and/or 99R01064-00-M-ECP : Anti-skid adhesives in the cockpit

## > CERTIFICATION ORGANIZATION(S)

EASA Europe

## > INSTALLATION TIME

QUALIFICATION	INSTALLATION DURATION
Airframe, Structure	2 Hour(s)

# Installation of 220V cabin converter

Reference: EC175-24-008 (R0)

Applicable to version(s): B

**The purpose of this Service Bulletin is to install the 220V cabin converter and activate the inhibited circuit breakers and switches.**

- This Service Bulletin consists in:
- Install the 220V cabin converter,
  - Remove the switch inhibitor,
  - Remove the lock-out rings.

SB from Airbus Helicopters France (AHF)



## > BENEFITS

- Install the 220V cabin converter

WEIGHT	MOMENT	DOWNTIME	LEAD TIME	PRICE RANGE	ONLINE CAT.
+5,477 kg	+25,662 m.kg	0,5 Day(s)	32 Week(s)	33523 EUR (e.c. 2023)	eOrdering

## > INSTALLATION TIME

QUALIFICATION	INSTALLATION DURATION
Airframe, Electrical	2 Hour(s)

## > PRE-POST REQUISITE / EFFECTIVITY

This service bulletin is applicable on helicopters S/N 5011, 5013, 5015, 5020, 5029, 5035 and 5037.

## > CERTIFICATION ORGANIZATION(S)

EASA Europe





# MAINTENANCE IMPROVEMENT



# Ground station retrofit - MGS V1.7

Reference: EC175-46-009 (R4)

Applicable to version(s): B

**The purpose of this Service Bulletin is to install the MGS (Maintenance Ground Station) V1.7 software. This update makes the latest standard of the ground station available and allows access to the latest upgrades, contributing to an improved functional performance.**

The modification consists in installing the MGS V1.7 software on the hardware. This installation is performed using the SIM (Software Installation Manual) X135P11S0107 document.

The retrofit can be performed by:

- either the installation of the MGS V1.7 software on a compatible equipment item
- or by acquiring an equipment item that is already configured by Airbus Helicopters

SB from Airbus Helicopters France (AHF)

The new MGS V1.7 ground station and the previous MGS ground stations are not interchangeable

## > BENEFITS

- The MGS V1.7 software allows the use of new functionalities described in the software user manuals for the MGS V1.7 HB X135P11S0107 software.

<b>WEIGHT</b>	<b>MOMENT</b>	<b>DOWN TIME</b>	<b>LEAD TIME</b>	<b>PRICE RANGE</b>	<b>ONLINE CAT.</b>
On request	On request	On request	On request	On request	eOrdering

## > INSTALLATION TIME

QUALIFICATION	INSTALLATION DURATION
Avionics, HUMS Specialist	4 Hour(s)



## > PRE-POST REQUISITE / EFFECTIVITY

This service bulletin is applicable on all H175 version B.

## > CERTIFICATION ORGANIZATION(S)

EASA Europe

# OBSOLESCENCE MANAGEMENT



# Back-up battery pack modification due to battery obsolescence

Reference: EC175-33-007 (R0)

Applicable to version(s): B

**The purpose of this Service Bulletin is to replace the battery due to obsolescence and to adapt the harnesses and the location of the connectors for the new battery.**

This Service Bulletin consists in:

- replacing the back-up battery pack,
- modifying the upper deck (Frame 3-4),
- modifying the RH and LH harnesses of the back-up battery pack,
- modifying the RH and LH HEELS ha

SB from Airbus Helicopters France (AHF)

PRE MOD and POST MOD equipment items are not interchangeable.

## > BENEFITS

- Replace the battery due to obsolescence

WEIGHT	MOMENT	DOWNTIME	LEAD TIME	PRICE RANGE	ONLINE CAT.
-0,984 kg to +0,712 kg (depending on aircraft configuration)	-5,127 m.kg to +4,868 m.kg (depending on aircraft configuration)	3 Day(s)	8 Week(s)	418 - 536 EUR (e.c. 2023)	eOrdering

## > INSTALLATION TIME

QUALIFICATION	INSTALLATION DURATION
Airframe	2 Hour(s)
Airframe, Electrical	20 Hour(s)

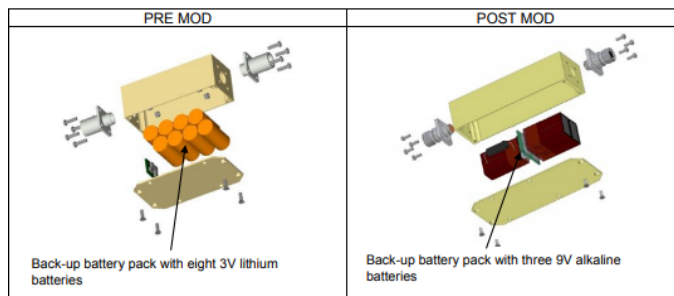

## > PRE-POST REQUISITE / EFFECTIVITY

This service bulletin is applicable on aircraft already equipped with :

- MOD 00A00115
- MOD 99A03339
- MOD 99A05143 or which have complied with ALERT SERVICE BULLETIN No. 25A022 (Unexpected WIS2 CPI503 beacon deployment orders)
- MOD 99A05809 or which have complied with ALERT SERVICE BULLETIN No. 25A022(Unexpected WIS2 CPI503 beacon deployment orders)

and not equipped with:

- MOD 99A05960
- MOD 99A05961
- MOD 99A05962
- MOD 99A05964

The following MOD also impact the applicability of the SB (will be selected in the CONFIGURATION ASSISTANT)

- MOD 00A00132
- MOD 99A04002
- MOD 99A05513
- MOD 99A03482
- MOD 99A03799
- MOD 99A03897

## > CERTIFICATION ORGANIZATION(S)

EASA Europe

# Replacement of cockpit and cabin fire extinguishers

Reference: EC175-26-001 (R0)

Applicable to version(s): B

## Replacement of cockpit and cabin fire extinguishers with their supports.

This Service Bulletin consists of:

- Replacing the cockpit fire extinguisher and its support
- Replacing the cabin fire extinguisher and its support

SB from Airbus Helicopters France (AHF)



### > BENEFITS

- The purpose of this Service Bulletin is to replace cockpit and cabin fire extinguishers with their supports, further to obsolescence.

WEIGHT	MOMENT	DOWNTIME	LEAD TIME	PRICE RANGE	ONLINE CAT.
Negligible	Negligible	1 Hour(s)	Depending on Spare Parts needed	Ref to detailed price online.	eOrdering

### > INSTALLATION TIME

QUALIFICATION	INSTALLATION DURATION
Airframe, Structure	1 Hour(s)

### > PRE-POST REQUISITE / EFFECTIVITY

This service bulletin is applicable on aircraft not equipped with :

- MOD 00A03575-00-M-ECP/00
- MOD 00A03613-00-M-ECP/00

The following informations also impact the applicability of the SB (will be selected in the CONFIGURATION ASSISTANT) :

- Replacement Cockpit fire extinguisher
- Replacement Cabin fire extinguisher

### > CERTIFICATION ORGANIZATION(S)

EASA Europe





# POWER PLANT RELATED OPTIONS



# Non-return valve modification

Reference: EC175-28-003 (R3)

Applicable to version(s): B

**The purpose of this Service Bulletin is to replace the non-return valves located in the fuel tanks (tanks 2, 3 and 6).**

This Service Bulletin consists in replacing the non-return valves of tanks 2, 3 and 6.

Helicopters which have complied with revision 1 of this Service Bulletin are not affected by revision 2 of this Service Bulletin.

SB from Airbus Helicopters France (AHF)

The non-return valves PRE MOD P/N 510398 (M282G20T2004) and POST MOD P/N 510398-2 (M282G20T3004) are interchangeable.

Following compliance with this Service Bulletin, the nonreturn valves PRE MOD P/N 510398 (M282G20T2004) and POST MOD P/N 510398-2 (M282G20T3004) will no longer be interchangeable.

Mixing between components P/N 510398 (M282G20T2004) and 510398-2 (M282G20T3004) is prohibited.



## > PRE-POST REQUISITE / EFFECTIVITY

This service bulletin is applicable on helicopters that have non-return valves P/N 510398 (M282G20T2004) and which have not complied with revision 0 of this Service Bulletin.

and not equipped with:

- MOD 00G02738 (NON-RETURN VALVE MODIFICATION)

## > CERTIFICATION ORGANIZATION(S)

EASA Europe

## > BENEFITS

- The dimension of the springs of the new non-return valves has been modified to prevent blocking in case of overlapping of the springs when in the open position.

WEIGHT	MOMENT	DOWN TIME	LEAD TIME	PRICE RANGE	ONLINE CAT.
Negligible	Negligible	7 Day(s)	18 Week(s)	7862 EUR (e.c. 2023)	eOrdering

## > INSTALLATION TIME

QUALIFICATION	INSTALLATION DURATION
Airframe, Mechanics	45 Hour(s) (excluding testing time)

# PRODUCT IMPROVEMENT



# Addition of a gutter with drains in the nose avionics bay

Reference: EC175-53-028 (R1)

Applicable to version(s): B

**The purpose of this Service Bulletin is to install a gutter to prevent water infiltration in the nose avionics bay.**

Compliance with this Service Bulletin consists in:

- removing the VOR 2 GLIDE harness,
- installing the gutter with drains,
- reinforcing the radome (for helicopter No. 5002 only),
- installing the VOR 2 GLIDE harness

Helicopters which have already complied with revision 0 of this Service Bulletin are concerned by revision 1 of this Service Bulletin.

SB from Airbus Helicopters France (AHF)

PRE MOD and POST MOD harnesses are not interchangeable.

Information Notice: 2832-I-00: Procedure for returning parts to Airbus Helicopters for overhaul/ repair/technical investigation/ core unit return (not attached to this Service Bulletin)

## > BENEFITS

- Prevent water infiltration in the nose avionics bay

WEIGHT	MOMENT	DOWN TIME	LEAD TIME	PRICE RANGE	ONLINE CAT.
+0,998 kg to +1,36 kg (depending on aircraft configuration)	+3,297 m.kg to +3,546 m.kg (depending on aircraft configuration)	0,5 to 3 Day(s) (depending on aircraft configuration)	26 Week(s)	15703 - 50048 EUR (e.c. 2023)	eOrdering

## > INSTALLATION TIME

QUALIFICATION	INSTALLATION DURATION
Airframe	2 to 4 Hour(s) (depending on aircraft configuration)
Airframe, Electrical	12 to 20 Hour(s) (depending on aircraft configuration)

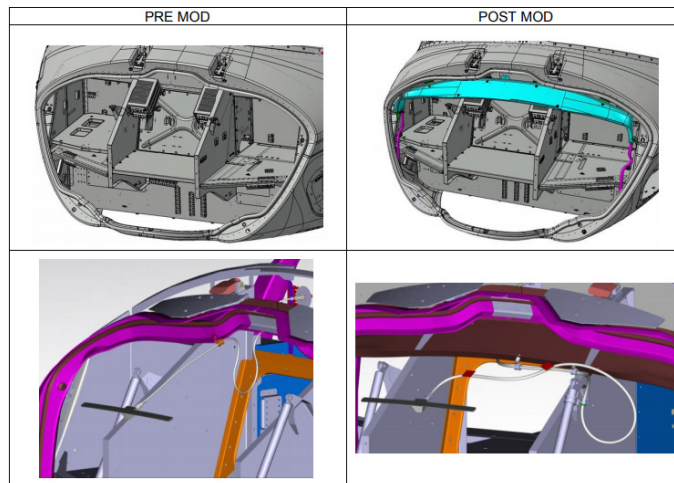

## > PRE-POST REQUISITE / EFFECTIVITY

This Service Bulletin is applicable on helicopters not equipped with:

- MOD 99A05339 (add gutter with draining in nose avionics bay),
- MOD 99A05804 (P170 - Elec\_Glide antenna harness support modification further to addition of gutter in NAB),
- MOD 99A05747 (P903 - Elec\_Glide antenna harness modification further to addition of gutter in NAB),
- or MOD 99A05755 (P909 - PS - Elec\_Glide antenna harness modification further to addition of gutter in NAB).

## > CERTIFICATION ORGANIZATION(S)

EASA Europe



# AMC from STEP 2 to STEP 2R

Reference: EC175-46-016 (R0)

Applicable to version(s): B

**The purpose of this Service Bulletin is to authorize this upgrade and to make the two AMCs interchangeable.**

This Service Bulletin consists in:

- Replacing the 2 AMC Step 2 systems with the Step 2R systems,
- Installing the HLX (HELIONIX) Step 3 SW (Software) and the PCF (Primary Configuration File) on the AMC Step 2 systems.

SB from Airbus Helicopters France (AHF)

PRE MOD and POST MOD components are interchangeable.  
Mixing between PRE MOD and POST MOD components is prohibited.



## > BENEFITS

- The goal is to give customers more flexibility during Aircraft On Ground (AOG) situations, based on the available spare parts.

WEIGHT	MOMENT	DOWNTIME	LEAD TIME	PRICE RANGE	ONLINE CAT.
+0,171 kg	+0,495 m.kg	0,5 Day(s)	On request	On request	eOrdering

## > INSTALLATION TIME

QUALIFICATION	INSTALLATION DURATION
Avionics	2 Hour(s)

## > PRE-POST REQUISITE / EFFECTIVITY

This service bulletin is applicable on aircraft equipped with:

- AMC Step 2 P/N MB0807D-22
- MOD 99A03944-00-M-ECP (Elec\_AMC from Step 2R to Step 2),

and not equipped with:

- MOD 99A05529-00-M-ECP/01 (Elec\_AMC from Step 2 to Step 2R).

## > CERTIFICATION ORGANIZATION(S)

EASA Europe

# Cable hoist protection

Reference: EC175-25C029 (R0)

Applicable to version(s): B

**The purpose of this Service Bulletin is to install a protective shim on the hoist beam to avoid interference with the hoist cable.**

This Service Bulletin consists in:

- Installing a protective shim on the hoist beam cowling reinforcement
- Installing a protective shim of the hoist beam frame.

SB from Airbus Helicopters France (AHF)

The ability to apply this Service Bulletin depends on the helicopter's configuration and will be verified as soon as the reply form sheet has been received.



## > BENEFITS

- To avoid interference with the hoist cable.

WEIGHT	MOMENT	DOWN TIME	LEAD TIME	PRICE RANGE	ONLINE CAT.
Negligible	Negligible	2 Hour(s) (excluding drying time)	On request	On request	eRFQ

## > INSTALLATION TIME

QUALIFICATION

Airframe

INSTALLATION DURATION

2 Hour(s)

## > PRE-POST REQUISITE / EFFECTIVITY

On request

## > CERTIFICATION ORGANIZATION(S)

EASA Europe



# Creation of a new bearing hanger assembly

Reference: EC175-65-006 (R0)

Applicable to version(s): B

**The purpose of this SB is to replace the bearing hanger and then enable the replacement of the drive shaft or the bearing hanger independently during the next maintenance operation.**

This Service Bulletin consists in:

- Replacing the bearing hanger assembly
- Identifying again the intermediate drive shaft assembly

Pre Mod -Post Mod intermediate drive shaft assemblies are interchangeable.

SB from Airbus Helicopters France (AHF)

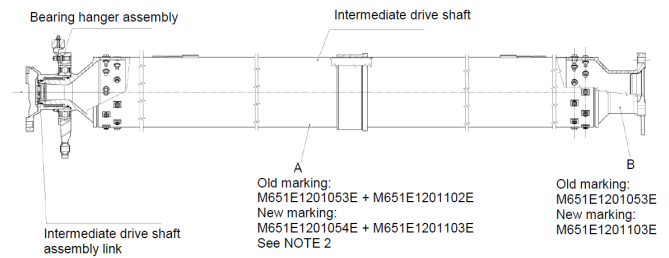

## > PRE-POST REQUISITE / EFFECTIVITY

Pre Mod 00E01060

## > CERTIFICATION ORGANIZATION(S)

EASA Europe

## > BENEFITS

- Improve maintenance and reduce costs

WEIGHT	MOMENT	DOWN TIME	LEAD TIME	PRICE RANGE	ONLINE CAT.
Negligible	Negligible	12 Hour(s)	Week(s)	17954 EUR (e.c. 2023)	eOrdering

## > INSTALLATION TIME

QUALIFICATION	INSTALLATION DURATION
Airframe, Mechanics	8 Hour(s)

# Drainage of the low point under TGB/IGB

Reference: EC175-53-030 (R1)

Applicable to version(s): B

**The purpose of this Service Bulletin is to improve the drain system of the tail boom under the Tail Gear Box (TGB) and the Intermediate Gear Box (IGB)**

This Service Bulletin consists in installing a new drain system under the IGB and the TGB.

SB from Airbus Helicopters France (AHF)

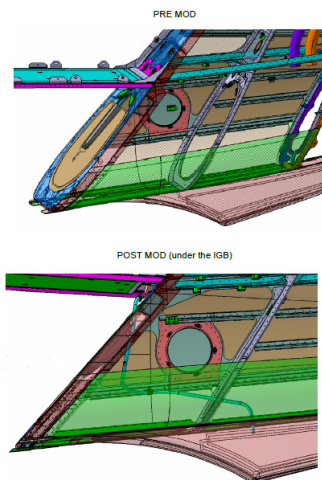

## > BENEFITS

- Improve the drain system of the tail boom under the Tail Gear Box (TGB) and the Intermediate Gear Box

WEIGHT	MOMENT	DOWN TIME	LEAD TIME	PRICE RANGE	ONLINE CAT.
Complete Installation +0,369 kg	Complete Installation +5,568 m.kg to +0,008 m.kg	8 Day(s)	Week(s)	11129 EUR (e.c. 2023)	eOrdering

## > INSTALLATION TIME

QUALIFICATION	INSTALLATION DURATION
Pilot, Functional Check	2 Hour(s)
Airframe, Structure	30 Hour(s)

## > PRE-POST REQUISITE / EFFECTIVITY

- Pre-MOD:
- 00E01069
  - 00G02512
  - 00H01222
  - 00H01226
  - 00H01229

## > CERTIFICATION ORGANIZATION(S)

EASA Europe

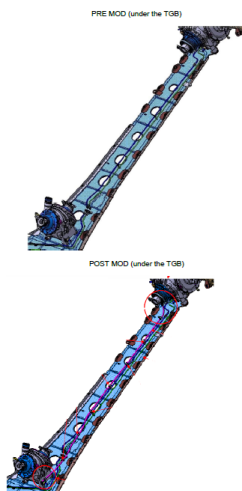

# Firewall lower vertical angles replacement

Reference: EC175-71-020 (R0)

Applicable to version(s): B

**The purpose of this Service Bulletin is to replace firewall lower vertical angles to improve their stiffness.**

This Service Bulletin consists in replacing lower vertical angles of the firewall by stiffener

SB from Airbus Helicopters France (AHF)

## BENEFITS

- Installation of reinforcement in the corners providing more firewall rigidity

WEIGHT	MOMENT	DOWN TIME	LEAD TIME	PRICE RANGE	ONLINE CAT.
Complete Installation +0,109 kg	Complete Installation +0,86 m.kg to -0,021 m.kg	4 Day(s)	Week(s)	6449 EUR (e.c. 2023)	eOrdering

## INSTALLATION TIME

QUALIFICATION

Airframe, Structure

INSTALLATION DURATION

4 Day(s)

No. EC175-71-020

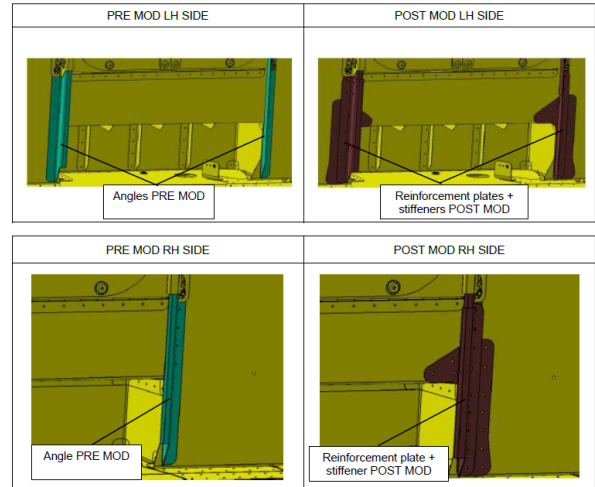
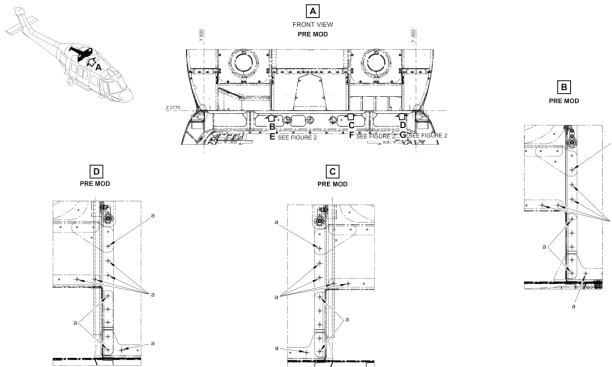

## PRE-POST REQUISITE / EFFECTIVITY

Pre Mod 99A06191

## CERTIFICATION ORGANIZATION(S)

EASA Europe

No. EC175-71-020

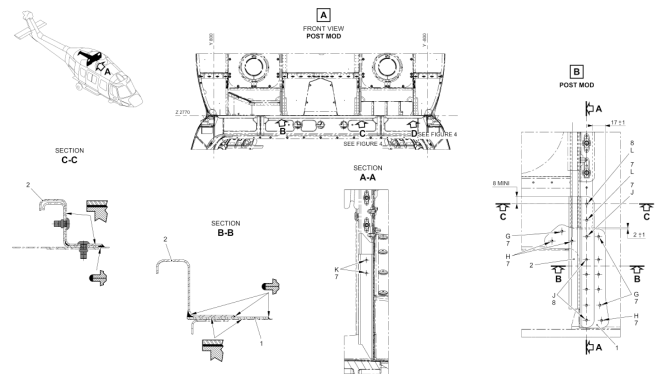



# Firewall Tunnel Reinforcement

Reference: EC175-71-021 (R0)

Applicable to version(s): B

**The purpose of this Service Bulletin is to replace firewall tunnel angles to improve their stiffness**

This Service Bulletin consists in:

- Removing the angles of the firewall tunnel and adapting the firewall tunnel
- Installing the new angles of the firewall tunnel.

SB from Airbus Helicopters France (AHF)

## > BENEFITS

- Improves stiffness by replacing the angles of the firewall tunnel to improve their rigidity

WEIGHT	MOMENT	DOWN TIME	LEAD TIME	PRICE RANGE	ONLINE CAT.
Complete Installation +0,28 kg	Complete Installation +2,395 m.kg to -0,002 m.kg	11 Day(s)	Week(s)	5588 EUR (e.c. 2023)	eOrdering

## > INSTALLATION TIME

QUALIFICATION	INSTALLATION DURATION
Airframe, Structure	88 Hour(s)

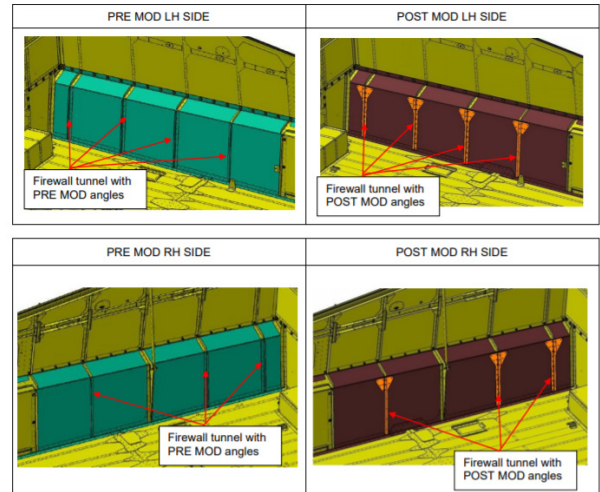
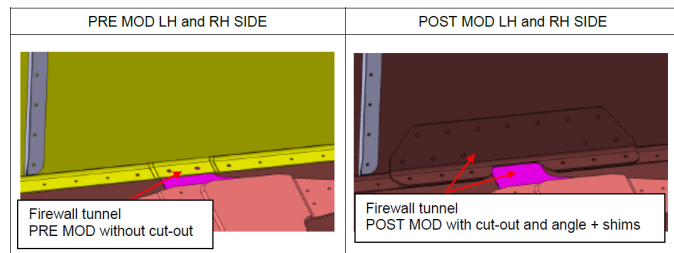

## > PRE-POST REQUISITE / EFFECTIVITY

Pre Mod 99A06192

## > CERTIFICATION ORGANIZATION(S)

EASA Europe

# Health and Usage Monitoring System (HUMS) - HMS Configuration file

Reference: EC175-31-009 (R1)

Applicable to version(s): B

**The purpose of this Service Bulletin is to upload a new configuration file in the DMAU (Dynamic Monitoring Acquisition Unit).**

This Service Bulletin consists in uploading the configuration file P/N M313A10S0301 in the DMAU.

Previous compliance with the following Service Bulletin is required for compliance with this Service Bulletin: Service Bulletin No. 46-009 (Ground station retrofit - MGS) Revision 4.

SB from Airbus Helicopters France (AHF)

Considering the different possible configurations, the adequate version will be defined as soon as your Request For Quotation is received (use the form below).



## > BENEFITS

- Currently, the DMAU configuration does not allow correct acquisition of vibration signals from the tail rotor. The "Autorange" function of the DMAU cannot transmit the appropriate gain for the PGA (Programmable Gain Amplifier which results in signal distortion and non-stable data reading.
- This update corrects the parameter setting and the acquisition quality of the vibration signal from the tail rotor by increasing the frequency of signal sampling.

## > PRE-POST REQUISITE / EFFECTIVITY

Helicopters/installed equipment or parts :

- POST MOD 99A04399 (P073\_Avoid missing data from DMAU and failed HMS function),
- which have the MGS V1.7 ground station installation (Maintenance Ground Station),
- PRE MOD 99A05797 (HMS Configuration file).

## > CERTIFICATION ORGANIZATION(S)

EASA Europe

WEIGHT	MOMENT	DOWN TIME	LEAD TIME	PRICE RANGE	ONLINE CAT.
Negligible	Negligible	0,5 Day(s)	On request	On Request	eRFQ

## > INSTALLATION TIME

QUALIFICATION	INSTALLATION DURATION
Avionics	2 Hour(s)

# HUMS - Definition of the vibration thresholds on the maintenance ground station (in VIP configuration)

Reference: EC175-31-007 (R5)

Applicable to version(s): B

**The purpose of this Service Bulletin is to update the threshold values on the Maintenance Ground Station (MGS) for use on EC175 helicopters in VIP configuration which have the Step 3 or Step 3.2 Version of the HELIONIX avionics suite.**

The goal of this Service Bulletin is to update the threshold values on the Maintenance Ground Station (MGS) for use on EC175 helicopters in VIP configuration which have the Step 3 or Step 3.2 Version of the HELIONIX avionics suite.

Comply with the Service Bulletin No. 46-009. (System Integration and Display - Ground Station Retrofit - MSG) beforehand, to upgrade the MGS ground station to version 1.7.

SB from Airbus Helicopters France (AHF)



## > CERTIFICATION ORGANIZATION(S)

EASA Europe

<b>WEIGHT</b>	<b>MOMENT</b>	<b>DOWN TIME</b>	<b>LEAD TIME</b>	<b>PRICE RANGE</b>	<b>ONLINE CAT.</b>
Negligible	Negligible	N/A	On request	On Request	eOrdering

## > INSTALLATION TIME

<b>QUALIFICATION</b>	<b>INSTALLATION DURATION</b>
Airframe, Mechanics	2 Hour(s) Airbus Helicopters approved technician

# HUMS : Definition of vibration thresholds on Maintenance Ground Station (MGS)

Reference: EC175-31-002 (R8)

Applicable to version(s): B

**This Service Bulletin gives the update of the threshold values defined on the Maintenance Ground Station (MGS) for H175 aircrafts fitted with the HELIONIX Step 3 or Step 3.2 version avionics suite.**

The purpose of Revision 8 of this Service Bulletin is to:

Update the threshold values for helicopters:

- which are equipped with the HELIONIX suite Version Step 3 or Step 3.2
- which have embodied modification 99A05797

Update the component of the indicators for helicopters:

- which are equipped with the HELIONIX suite Version Step 3 or Step 3.2
- which have embodied modification 99A05797

Update the Service Bulletin to the new format

HUMS thresholds were implemented in the ground station by Airbus Helicopters. Integrate new HUMS threshold values in the MGS using the ground station Operator's guide.



## > CERTIFICATION ORGANIZATION(S)

EASA Europe

SB from Airbus Helicopters France (AHF)

## > BENEFITS

- Insure monitoring of Aircraft vibration in the MGS (Maintenance Ground Station).

WEIGHT	MOMENT	DOWN TIME	LEAD TIME	PRICE RANGE	ONLINE CAT.
Negligible	Negligible	N/A	On request	On request	eRFQ

## > INSTALLATION TIME

QUALIFICATION	INSTALLATION DURATION
Airframe, Systems	2 Hour(s) Airbus Helicopter-Approved technician

# Improvement of maintenance during installation of the hoist

Reference: EC175-25-007 (R0)

Applicable to version(s): B

**The purpose of this Service Bulletin is to improve maintenance during installation of the hoist.**

The purpose of this Service Bulletin is to install 2 plastics protections at the end of the hoist attachments.

SB from Airbus Helicopters France (AHF)



## > BENEFITS

- Preventing marks on the holes of the frames attaching the hoist to the helicopter.

WEIGHT	MOMENT	DOWN TIME	LEAD TIME	PRICE RANGE	ONLINE CAT.
+ 0,1 kg	+ 0.71 m.kg	1 Hour(s)	Depending on Spare Parts needed	Ref to detailed price online.	eOrdering

## > INSTALLATION TIME

QUALIFICATION	INSTALLATION DURATION
Airframe, Structure	1 Hour(s)

## > PRE-POST REQUISITE / EFFECTIVITY

This service bulletin is applicable on aircraft already equipped with :

- GOODRICH (class 1) variable-speed electrical hoist of 42325 type. and not equipped with :
- 00A04005-00-M-ECP/00 : Improvement of maintenance during installation of the hoist

## > CERTIFICATION ORGANIZATION(S)

EASA Europe

# Improvement of the cargo doors holding system

Reference: EC175-52-002 (R0)

Applicable to version(s): B

**Improve the cargo doors holding system and reinforce their supports so as to make their full opening possible.**

- This Service Bulletin consists of :
- Removing the cargo doors
  - Replacing the gas spring supports
  - Replacing the gas springs
  - Re-installing the cargo doors

SB from Airbus Helicopters France (AHF)

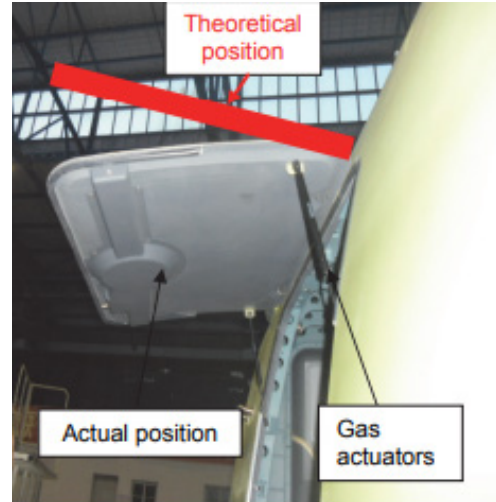

## > BENEFITS

- Make the full opening of the doors possible and their access easier.

WEIGHT	MOMENT	DOWNTIME	LEAD TIME	PRICE RANGE	ONLINE CAT.
Negligible	Negligible	12 Hour(s)	6 Week(s)	5635 EUR (e.c. 2023)	eOrdering

## > INSTALLATION TIME

QUALIFICATION	INSTALLATION DURATION
Airframe, Electrical	2 Hour(s)

## > PRE-POST REQUISITE / EFFECTIVITY

- This service bulletin is applicable on aircraft not equipped with :
- MOD 00A03952-00-M-ECP/01 : Improvement of the cargo doors holding system

## > CERTIFICATION ORGANIZATION(S)

EASA Europe

# Improvement of the Nose landing gear with new frame assembly

Reference: EC175-32-005 (R0)

Applicable to version(s): B

**This Service Bulletin is to replace the "A" frame assembly of the Nose Landing Gear (NLG) with a new "A" frame assembly with Axis Mechanism Redesign.**

This Service Bulletin consists in:

- Removing the old NLG "A" frame assembly
- Installing the new NLG "A" frame assembly

SB from Airbus Helicopters France (AHF)

No. EC175 32-005

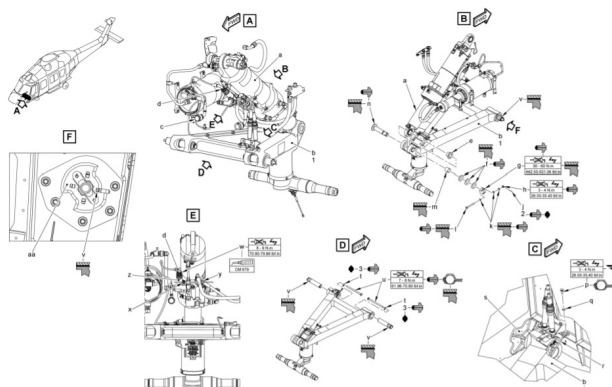

## > BENEFITS

- Replace the "A" frame assembly of the Nose Landing Gear with a new "A" frame assembly that has a new design to prevent difficulties in turning.

WEIGHT	MOMENT	DOWN TIME	LEAD TIME	PRICE RANGE	ONLINE CAT.
Complete Installation +0,058 kg	Complete Installation +0.27 m.kg to -0.005 m.kg	2 Day(s)	On request	On request	eOrdering

## > PRE-POST REQUISITE / EFFECTIVITY

Pre Mod 99A05940

## > CERTIFICATION ORGANIZATION(S)

EASA Europe

## > INSTALLATION TIME

QUALIFICATION	INSTALLATION DURATION
Airframe, Mechanics	2 Day(s)



# Landing Gear Equipment TITEFLEX Pipe Replacement

Reference: EC175-29-002 (R0)

Applicable to version(s): B

**The purpose of this Service Bulletin is to replace the TITEFLEX hydraulic pipes of the front landing gear.**

This Service Bulletin consists in replacing the TITEFLEX pipes of the landing gear and the brackets used to mount some of those pipes.

SB from Airbus Helicopters France (AHF)

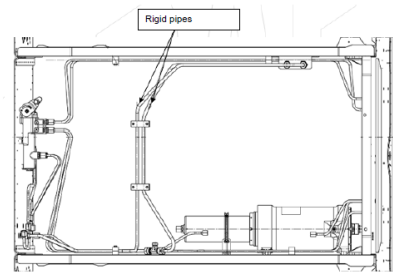
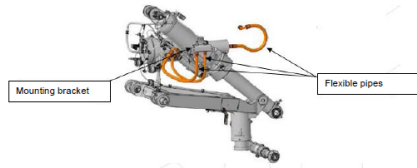

## > BENEFITS

- News Hydraulic Pipe & News Flexible Pipe due to obsolescence .

WEIGHT	MOMENT	DOWN TIME	LEAD TIME	PRICE RANGE	ONLINE CAT.
Negligible	Negligible	13 Hour(s)	Week(s)	4294 EUR (e.c. 2023)	eOrdering

## > INSTALLATION TIME

QUALIFICATION	INSTALLATION DURATION
Airframe, Structure	12 Hour(s)

## > PRE-POST REQUISITE / EFFECTIVITY

Pre Mod 99A05459  
Pre Mod 00G02696

## > CERTIFICATION ORGANIZATION(S)

EASA Europe

# Multifunction Displays - Aircraft Management Computer

Reference: EC175-31-010 (R2)

Applicable to version(s): B

**The purpose of this Service Bulletin is to provide an update of the EC175 HELIONIX V8.0 Step 3.2**

The purpose of the modification is to:

- Upgrade the HELIONIX Software for AMC STEP2 hardware type or AMC STEP2R
- Upgrade the HELIONIX Software for MFD, to solve the Software problems and to increase the capacities
- Upload databases
- Remove the following placards from the instrument panel

During compliance with this Service Bulletin, jointly comply with SB No. 46-009 (Ground Station Retrofit -MGS V1.6 or UPPER)

SB from Airbus Helicopters France (AHF)



## > BENEFITS

- Provide an update of the EC175 HELIONIX V8.0 Step 3.2 suite to improve customer satisfaction.

WEIGHT	MOMENT	DOWNTIME	LEAD TIME	PRICE RANGE	ONLINE CAT.
Negligible	Negligible	5 Hour(s)	On request	On request	eOrdering

## > INSTALLATION TIME

QUALIFICATION	INSTALLATION DURATION
Avionics	3 Hour(s)

## > PRE-POST REQUISITE / EFFECTIVITY

Post Mod:00A03946,99A03943,99A03944,99A03945,99A03983,99A04924,99A05529.

Pre Mod:99A05288 or 99A05289.

Pre Mod:99A05290,99A05682,99A05683,99A0575.

## > CERTIFICATION ORGANIZATION(S)

EASA Europe

# New design of seals in bottom structure fairings

Reference: EC175-53-033 (R0)

Applicable to version(s): B

**The purpose of this Service Bulletin is to replace the seals of the bottom structure fairings.**

This Service Bulletin consists in replacing the seals of the bottom structure fairings.

SB from Airbus Helicopters France (AHF)



## > BENEFITS

- New material more resistant to fuel concerning the seals of the fairings ( bottom Structure )

WEIGHT	MOMENT	DOWN TIME	LEAD TIME	PRICE RANGE	ONLINE CAT.
Negligible	Negligible	5 Day(s)	Week(s)	86188 EUR (e.c. 2023)	eOrdering

## > PRE-POST REQUISITE / EFFECTIVITY

## > CERTIFICATION ORGANIZATION(S)

EASA Europe

## > INSTALLATION TIME

QUALIFICATION	INSTALLATION DURATION
Airframe, Structure	40 Hour(s)

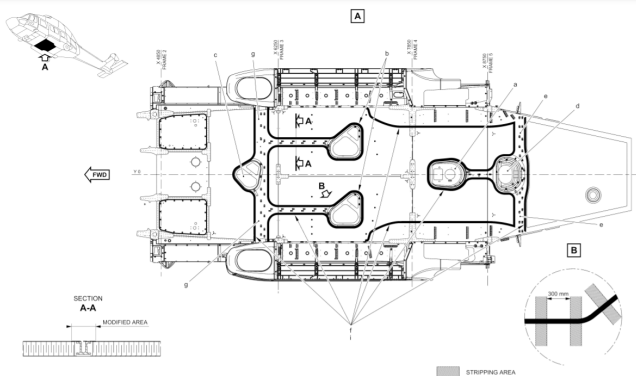

# New Inertia Switch (CVFDR)

Reference: EC175-31-004 (R1)

Applicable to version(s): B

The purpose of this Service Bulletin is to replace the CVFDR (Cockpit Voice and Flight Data Recorder) inertia switch P/N SP3810 with a shock sensor, P/N 3LO-927-6.

This Service Bulletin consists in:

- Removing the existing inertia switch from frame 8
- Modifying frames 6 and 8
- Installing a shock sensor on the frame 6
- Modifying the harness

Revision 1 of this SB to integrate PRE and POST MOD figures and to locate "41UB2A A" and "706VT 1" connectors.

SB from Airbus Helicopters France (AHF)

Pre Mod and Post Mod inertia switches are not interchangeable.

## > BENEFITS

- This new shock sensor can be re-initialized after being triggered, is moved from frame 8 to frame 6 to facilitate access and avoid untimely triggering.

WEIGHT	MOMENT	DOWN TIME	LEAD TIME	PRICE RANGE	ONLINE CAT.
Complete Installation +0,116 kg to +0,076 kg	Complete Installation +1,033 m.kg to +0,775 m.kg	4 Day(s)	Week(s)	5965 EUR (e.c. 2023)	eOrdering

## > INSTALLATION TIME

QUALIFICATION	INSTALLATION DURATION
Airframe, Electrical	25 Hour(s)
Airframe, Structure	4 Hour(s)

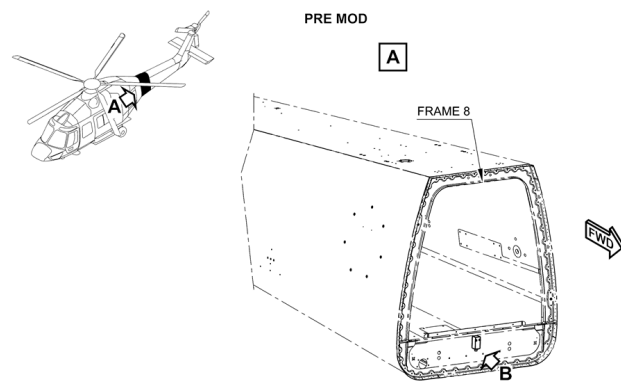
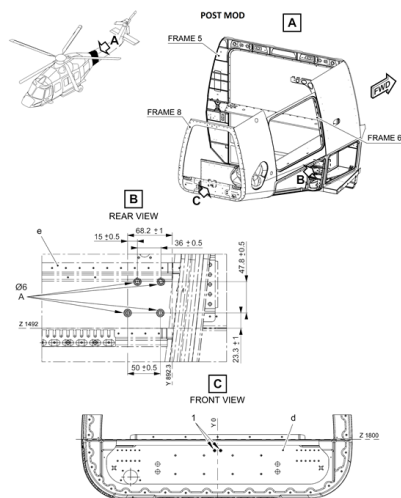

## > PRE-POST REQUISITE / EFFECTIVITY

Pre Mod :

- 00A03807-00-M-ECP
- 00A04908-00-M-ECP
- 99A04921-00-M-ECP
- 00A04922-00-M-ECP
- 00A04923-00-M-ECP

## > CERTIFICATION ORGANIZATION(S)

EASA Europe

# Relocation of HEELS Power Supply Units

Reference: EC175-25-046 (R0)

Applicable to version(s): B

**The purpose of this Service Bulletin is to move the Power Supply Units (PSU) of the HEELS (Helicopter Emergency exit lighting system) from the passenger compartment zone to the cockpit zone on the pilot side.**

This Service Bulletin consists in:

- Removing the HEELS PSUs from the passenger compartment zone,
- Installing the links for the HEELS PSUs in the cockpit zone,
- Installing the HEELS PSUs in the cockpit zone,
- Performing the routing and connection of the new wiring

SB from Airbus Helicopters France (AHF)

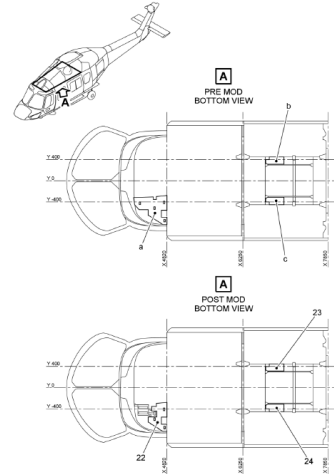

## > BENEFITS

- Emergency Exit Lighting System from the passenger compartment zone to the cockpit zone on the pilot side to
- improve maintenance operations on VIP helicopters

WEIGHT	MOMENT	DOWNTIME	LEAD TIME	PRICE RANGE	ONLINE CAT.
Complete Installation +0,351 kg	Complete Installation -0.565 m.kg to +0,617 m.kg	13 Hour(s)	Week(s)	6907 EUR (e.c. 2023)	eOrdering

## > INSTALLATION TIME

QUALIFICATION	INSTALLATION DURATION
Airframe, Structure	7 Hour(s)
Airframe, Electrical	4 Hour(s)

## > PRE-POST REQUISITE / EFFECTIVITY

Post Mod 99A03482  
Pre Mod 99A06001  
Pre Mod 99A06002.

## > CERTIFICATION ORGANIZATION(S)

EASA Europe

# Replacement of the access hatches of the last engine firewall

Reference: EC175-71-013 (R0)

Applicable to version(s): B

**The purpose of this Service Bulletin is to install new access hatches on the engine firewall to improve locking.**

This Service Bulletin consists in:

- Replacing the LH and RH access hatches on the firewall,
- Adding the reinforcement sheets inside the firewall
- Installing a reinforcement plate between the access hatch and the lateral firewall,
- Replacing the lower quick release fasteners of the firewall access hatches.

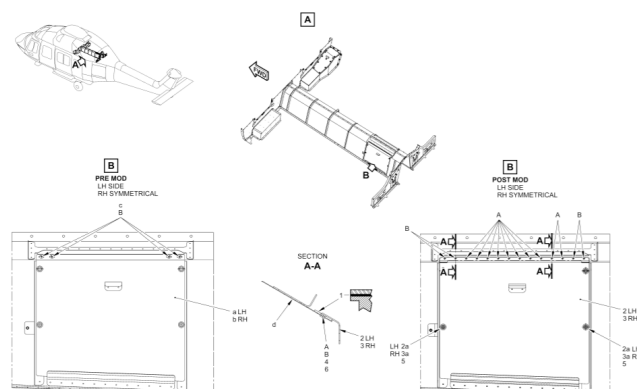

SB from Airbus Helicopters France (AHF)

## > BENEFITS

- Consist in installing new access hatches on the firewall.

WEIGHT	MOMENT	DOWN TIME	LEAD TIME	PRICE RANGE	ONLINE CAT.
Complete Installation +0,067 kg	Complete Installation +0,63 m.kg	4 Hour(s)	Week(s)	Ref to detailed price online.	eOrdering

## > INSTALLATION TIME

QUALIFICATION	INSTALLATION DURATION
Airframe, Structure	3 Hour(s)
Pilot, Functional Check	0,5 Hour(s)

## > PRE-POST REQUISITE / EFFECTIVITY

Pre Mod 00G02399-00  
Pre Mod 00G02545-00  
Post Mod 00G02279-00

## > CERTIFICATION ORGANIZATION(S)

EASA Europe

# Replacement of the label on the bearing support assembly of the tail drive line

Reference: EC175-65-005 (R1)

Applicable to version(s): B

**The purpose of this Service Bulletin is to make sure that grease P/N DC-SEA395 is used in maintenance on the bearing support assembly of the tail drive line.**

This Service Bulletin consists in replacing the greasing indication label (AIR 4210/G.354) of the bearing support assembly for the tail drive line with a greasing label (AIR 4222/G.395).

Helicopters which have already complied with revision 0 of this Service Bulletin are not concerned by revision 1 of this Service Bulletin.

SB from Airbus Helicopters France (AHF)

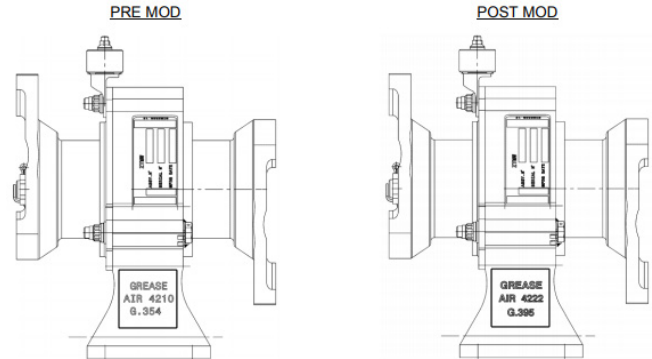

## > BENEFITS

- Make sure that grease P/N DCSEA395 is used in maintenance on the bearing support assembly of the tail drive line

WEIGHT	MOMENT	DOWN TIME	LEAD TIME	PRICE RANGE	ONLINE CAT.
On request	On request	0,5 Day(s)	On request	On request	eOrdering

## > INSTALLATION TIME

QUALIFICATION	INSTALLATION DURATION
Airframe	3 Hour(s)

## > PRE-POST REQUISITE / EFFECTIVITY

This service bulletin is applicable on aircraft already equipped with :

- MOD 00E01045 (TDL bearing support assy modification for bearing clearance) with a bearing support assembly of the tail drive line P/N M651E4201057 with a greasing indication label (AIR 4210/G.354)

and not equipped with:

- MOD 00E01061 (Correction of the TDL double bearing support lubrication label)

## > CERTIFICATION ORGANIZATION(S)

EASA Europe



# Replacement of the tail fairing fasteners and adaptation of the fairings

Reference: EC175-53-019 (R2)

Applicable to version(s): B

**The purpose of this Service Bulletin is to replace the quick release fastener system on the fairings of the tail boom, pylon, IGB( intermediate Gear Box) and TGB (Tail Gear Box) assembly to improve their attachments.**

This Service Bulletin consists in:

- Removing the fairings from the tail boom, the IGB, the pylon, and the TGB,
- Modifying the fixed parts to receive the new fairings or the modified fairings,
- Modifying the existing fairings,
- Installing the modified or ordered fairings.

Compliance with this Service Bulletin is not compatible with helicopters Post Mod 00A04942 and Post Mod 00A04943

SB from Airbus Helicopters France (AHF)

## > BENEFITS

- Improved closing system, more efficient and faster for all fairings.

WEIGHT	MOMENT	DOWN TIME	LEAD TIME	PRICE RANGE	ONLINE CAT.
Complete Installation +1,647 kg	Complete Installation +23,372 m.kg to +0,102 m.kg	22 Day(s) 1st case: 10 days - 2nd case: 22days	Week(s)	80766 EUR (e.c. 2023)	eOrdering

## > INSTALLATION TIME

QUALIFICATION	INSTALLATION DURATION
Airframe, Structure	10 to 22 Day(s)

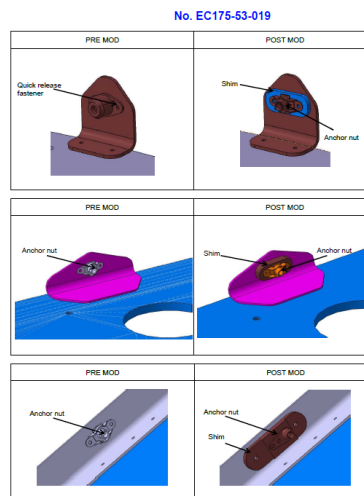
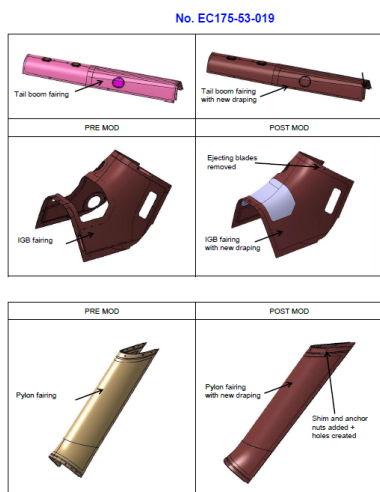

## > PRE-POST REQUISITE / EFFECTIVITY

Pre Mod:00A05281

Pre Mod:00A05282

Post Mod 00A05391 or which have complied with Service Bulletin No. EC175-53-022.

## > CERTIFICATION ORGANIZATION(S)

EASA Europe

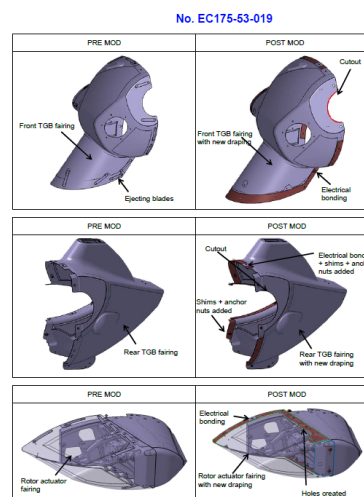

SAFETY



# Hand Fire Extinguisher

Reference: EC175-26-005 (R0)

Applicable to version(s): B

## Installation of halon-free hand fire-extinguisher in the cockpit

This Service Bulletin includes the work steps that follow:

- Removal of the halon-type hand fire-extinguisher and its bracket from the console of the cockpit
- Installation of the new halon-free hand fire-extinguisher, the bracket and the shim with new type screws on the console of the cockpit.

Interchangeability: Pre mod/ Post Mod helicopters is not permitted

Mixability: Not applicable

SB from Airbus Helicopters France (AHF)

### > BENEFITS

- The new hand fire-extinguisher uses a new extinguishing agent known as 2-bromotrifluoropropene (2-BTP).

KG	MOMENT	DOWN TIME	LEAD TIME	PRICE RANGE	ONLINE CAT.
Complete Installation +0,739 kg	Complete Installation +3,415 m.kg	1 Hour(s)	On request	On request	eOrdering

### > INSTALLATION TIME

QUALIFICATION	INSTALLATION DURATION
Airframe, Mechanics	1 Hour(s)

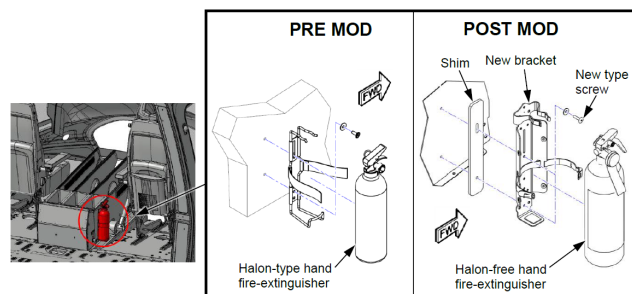

### > PRE-POST REQUISITE / EFFECTIVITY

Related to modifications (pre mod): 99A05475 and 99A05479

### > CERTIFICATION ORGANIZATION(S)

EASA Europe

# Protection against ice impacts on horizontal stabilizer

Reference: EC175-55-001 (R0)

Applicable to version(s): B

**The purpose of this Service Bulletin is to protect horizontal stabilizer from damage of ice.**

This Service Bulletin consists in:

- Installing the Fixed Part
- Installing the protection plate (Removable Part)
- Installing the anti-optional equipment

SB from Airbus Helicopters France (AHF)



## > BENEFITS

- Protection plate in order to improve the resistance of the LH horizontal stabilizer against ice impacts.

WEIGHT	MOMENT	DOWN TIME	LEAD TIME	PRICE RANGE	ONLINE CAT.
+ 2,026 kg	+ 32,2 m.kg	12 Hour(s)	26 Week(s)	6123 EUR (e.c. 2023)	eOrdering

## > INSTALLATION TIME

QUALIFICATION	INSTALLATION DURATION
Airframe, Structure	4 Hour(s)

## > PRE-POST REQUISITE / EFFECTIVITY

This service bulletin is applicable on aircraft not equipped with :

- MODs 99A04273-00-M-ECP/01 : Protection against ice impacts on horizontal stabilizer

## > CERTIFICATION ORGANIZATION(S)

EASA Europe

# Replacement of halon-free hand fire-extinguisher on the lower rear panel of the cabin

Reference: EC175-26-006 (R0)

Applicable to version(s): B

## Halon-free hand fire extinguisher installation on the lower rear panel of the cabin

Removal of the halon-type hand fire-extinguisher and its bracket from the lower rear panel of the cabin  
 Installation of the new halon-free hand fire-extinguisher and the new bracket with new type screws on the lower rear panel.

Interchangeability: Pre mod/ Post Mod helicopters is not permitted

Mixability: Not applicable

SB from Airbus Helicopters France (AHF)

Replacement of halon-free hand fire-extinguisher on the lower rear panel of the cabin

### > BENEFITS

- The new hand fire-extinguisher uses a new extinguishing agent known as 2-bromotrifluoropropane (2-BTP).

WEIGHT	MOMENT	DOWN TIME	LEAD TIME	PRICE RANGE	ONLINE CAT.
Complete Installation +0,613 kg	Complete Installation +5,316 m.kg	1 Hour(s)	On request	On request	eOrdering

### > INSTALLATION TIME

QUALIFICATION	INSTALLATION DURATION
Airframe, Mechanics	1 Hour(s)

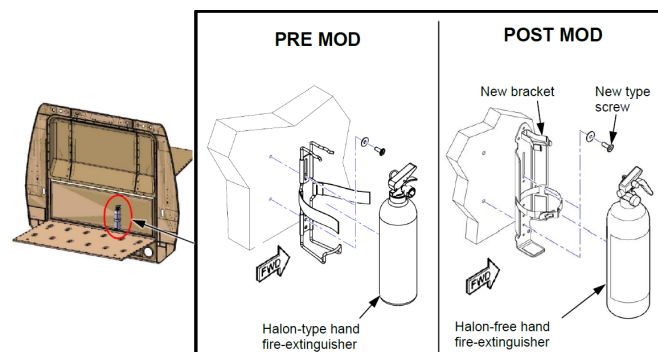

### > PRE-POST REQUISITE / EFFECTIVITY

PreMOD: to modifications 99A05474 and 99A05480

### > CERTIFICATION ORGANIZATION(S)

EASA Europe

# Replacement of hand fire extinguisher without Halon in the cabin (17 or 18 pax)

Reference: EC175-26-007 (R0)

Applicable to version(s): B

## Installation of halon-free hand fire-extinguisher in the cabin for 17 or 18 pax cabin layout configuration.

Removal of the halon-type hand fire-extinguisher and the fire extinguisher bracket from the cabin

Removal of the bracket assembly from the cabin floor

Installation of the bracket assembly, the new fire extinguisher bracket and the new halon-free hand fire-extinguisher.

SB from Airbus Helicopters France (AHF)

Interchangeability: Pre Mod / Post Mod helicopters is not permitted.

Mixability: Not applicable

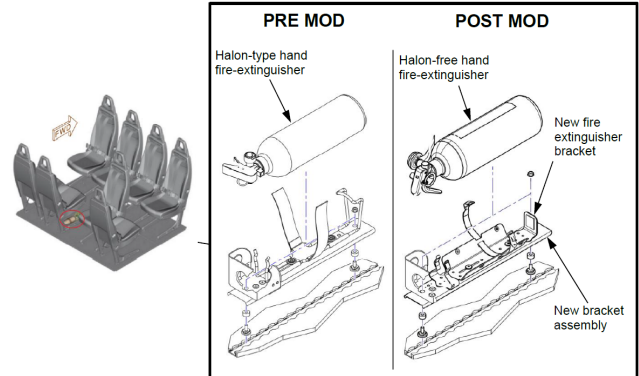

### > BENEFITS

- The new hand fire-extinguisher uses a new extinguishing agent known as 2-bromotrifluoropropene (2-BTP).

### > PRE-POST REQUISITE / EFFECTIVITY

Related to modifications( pre mod ): 99A05476, 99A05827 and 99A05481

### > CERTIFICATION ORGANIZATION(S)

EASA Europe

WEIGHT	MOMENT	DOWN TIME	LEAD TIME	PRICE RANGE	ONLINE CAT.
Complete Installation +0,465 kg	Complete Installation +2,755 m.kg	1 Hour(s)	On request	On request	eOrdering

### > INSTALLATION TIME

QUALIFICATION	INSTALLATION DURATION
Airframe, Mechanics	1 Hour(s)

# Winter kit installation

Reference: EC175-71-004 (R0)

Applicable to version(s): B

**The purpose of this Service Bulletin is to install a winter kit.**

- This Service Bulletin consists in:
- Drilling the air intake gutter holes
  - Drilling the air intake grid holes
  - Installing the masks
  - Replacing the top plenums

SB from Airbus Helicopters France (AHF)



## > BENEFITS

- To limit the build-up of snow and ice in the plenum while hovering and in forward flight.

WEIGHT	MOMENT	DOWN TIME	LEAD TIME	PRICE RANGE	ONLINE CAT.
+ 4.332 kg	+ 36.087 m.kg	1.5 Day(s)	104 Week(s)	55315 EUR (e.c. 2023)	eOrdering

## > INSTALLATION TIME

QUALIFICATION	INSTALLATION DURATION
Airframe, Structure	10 Hour(s)

## > PRE-POST REQUISITE / EFFECTIVITY

- This service bulletin is applicable on aircraft already equipped with :
- MOD 99A04331-00-M-ECP (HELIONIX V5.1 Step 2+ SW for Step 2 PTF)
- or
- MOD 99A04332-00-M-ECP (HELIONIX V5.1 Step 2+ SW for Step 2 R PTF)
- and not equipped with :
- MOD 99A04289-00-M-ECP (Winter kit fixed parts)
  - MOD 99A04290-00-M-ECP (Winter kit plenums)
  - MOD 99A04291-00-M-ECP (Winter kit masks)

## > CERTIFICATION ORGANIZATION(S)

EASA Europe





# Standard Conditions of Sale

---

## 1 - DEFINITIONS

- Affiliate means a company which Controls or is Controlled by respectively the Customer or the Airbus Helicopters group of companies.

- AOG (Aircraft On Ground) means a situation in which the Helicopter is unable to fly or is ineligible to return to service because of an unscheduled need for replacement or major repair of components, that is not related to scheduled maintenance tasks.

- BFE/CFE means Buyer Furnished Equipment / Customer Furnished Equipment.

- Certificate of Conformity (or Statement of Conformity) means the document issued by the Seller's quality assurance organization after completion of procedures approved by the respective authorized national agency certifying the Product's conformity with the Seller's applicable specifications.

- CAMO means Continuing Airworthiness Management Organization.

- Contract means the agreement between the Parties of which these Standard Conditions of Sale form part, comprising the applicable Specific Annex(es) and the Purchase Order or Order Confirmation.

- Control (including with correlative meanings the terms "controlling", "controlled" and "under common control with"), with respect to any natural or legal person, means the possession, directly or indirectly, whether through ownership of voting securities, by contract or otherwise of: a majority of the voting rights exercisable at general meetings of the controlled undertaking on all, or substantially all, matters, or, the power to appoint or remove directors having a majority of the voting rights exercisable at meetings of the board of directors on all, or substantially all, matters ; or a power to exert a dominant influence over the affairs of the controlled undertaking.

- Core Unit means the used Part sent by the Customer to the Seller in case of exchange for an overhauled or repaired Part under the standard exchange service.

- Customer means the person, entity, or company to whom the Seller sells any Products and/or Services under the Contract.

- Customer Centre means a subsidiary or an Affiliate of Airbus Helicopters (SAS).

- Documentary Credit means an irrevocable, confirmed and non-transferable documentary credit.

- EASA means European Aviation Safety Agency.

- Helicopter means helicopter manufactured by Airbus Helicopters (SAS) (H125, H130, H160, H175, H215 and H225) or by Airbus Helicopters Deutschland GmbH (H135 and H145).

- IT Service Provider(s) mean(s) a third parties(y) contracted by the receiving Party that provide(s) IT services, project management services or other office management services and which may have administrative rights to sustain the IT systems.

- Item means hardware, software, technical data/technology(ies) and/or services.

- Order Confirmation means the acknowledgement of receipt of the Customer's order by the Seller, i.e. either the confirmation sent by the Seller to the Customer to take into account the Customer's order or the approval sent by the Customer to the Seller on the Quotation.

- Part means a physical good defined with a part number.

- Party/Parties mean either separately or collectively the Customer and/or the Seller.

- Product(s) means the goods to be provided by the Seller under the Contract in compliance with the applicable specification and/or definition, including all types of Helicopters, optional equipment, Spare Parts, tools, other equipment, documentation, technology, data, software on a Product (and any other goods mentioned in the Specific Annex(es), when applicable).

- Production Organization Approval (POA) means approvals issued by the respective competent authority to the Seller in compliance with EASA part 21/G regulation.

- Purchase Order (or Order) means the order covering the acquisition of Products and/or Services.

- Quotation means the priced offer and associated conditions, sent to the Customer by the Seller.

- R&O means the following activities: repair, overhaul, standard exchange, inspection and modification of a Part.

- RMA means Return Material Authorization format provided by the Seller for the purposes of the warranty article and/or R&O Service.

- Seller means Airbus Helicopters (SAS) located in Marignane, France (referred to as "AH") and/or Airbus Helicopters Deutschland GmbH (referred to as "AHD"), located in Donauwörth, Germany.

- Service(s) means the services which may be performed under the Contract consisting of: performance of R&O Technical Data, technical assistance, technical expert services, and/or tool rental performance of Training, SaaS, and any other services mentioned under the Specific Annex(es), when applicable. The specific Service(s) to be provided by the Seller under the Contract are specified therein.

- SaaS (Software As A Service) means a software application available online on an internet website and/or a software application available on defined mobile operating system(s).

- Specific Annex (or Annex) means the annex of the SCS outlining specific conditions.

- Spare Parts means new parts provided by the Seller.

- SCS means these general Standard Conditions of Sale for Products and Services.

- SB means Service Bulletin.

- STC means Supplemental Type Certificate and also refers to an equipment which has a STC.

- TAT means Turn Around Time, from the time the Seller receives the Customer's Part and its related and valid documents in its facility up to the time the Part is at the Customer's disposal Free Carrier (FCA) Incoterms® 2020 at Seller's facility, less the Customer's approval lead time and/or less lead time due to Customer's responsibility discrepancies.

- Technical Data (or TechData) means technical publications provided by the Seller.

- Training Items means training software, training documentation and courseware.

- Training means training need analysis, training courses, simulator sessions and on-the-job training.

- TSN, TSO, TSR, TBO, OTL, SLL mean respectively Time Since New, Time Since Overhaul, Time Since Repair, Time Between Overhaul, Operating Time Limit and Service Life Limit.

- VAT means Value Added Tax.

## 2 - SUBJECT AND SCOPE

These general Standard Conditions of Sale apply to any sale of Products and/or Services sold by the Seller to its Customer(s), excluding brokerage or other distributor activities. The purchase of the Products and/or Services by a Customer is considered to be performed within the framework of its professional activities.

These general Standard Conditions of Sale are supplemented by the relevant Specific Annex(es) as quoted hereinafter, when applicable:

- for Helicopter sales:

- Sale of new Helicopters and associated services
- Sale of pre-owned Helicopters and associated services

- and for Products (other than Helicopters) and Services:

- Sale of Spare Parts
- R&O Services
- Technical Data, technical assistance, technical expert services, tool rental
- Training Services and Training Items
- Helicopter maintenance, repair, overhaul, inspection, upgrade and retrofit
- SaaS

## 3 - PURCHASE ORDER / QUOTATION

## 3.1 Sale of Helicopters and associated Services – Purchase Order

The Contract shall be binding when signed by duly authorised representatives of both Parties and the delivery schedule shall become effective upon receipt by the Seller of the initial downpayment and subject to compliance by the Customer to article 4.1.

## 3.2 Products and Services sold independently of a Helicopter sale – Order issuance, acceptance

Customer's Orders shall be confirmed by the Seller in writing. The Contract shall become binding upon receipt by the Customer of the Seller's Order Confirmation and the delivery schedule shall become effective upon receipt by the Seller of the down-payment when relevant (as mentioned under article 6.2) and subject to compliance by the Customer to article 4.1.

In case the Customer requires a Quotation from the Seller, the Contract shall become binding when the Seller receives the Customer's written approval of such Quotation issued without changes. Said Quotation duly signed by the Customer shall constitute the Order Confirmation when received by the Seller.

## 3.3 Purchase Order modifications

### 3.3.1 Modifications to Purchase Order by the Seller

Pursuant to new manufacturing or engineering requirements, obsolescence or new regulations, the Seller shall be entitled to carry out modifications without the consent of the Customer, as long as these modifications do not affect the specification and/or performance of the Product and/or Services, and/or delivery time. Should the requirements affect specification and/or performance of the Product and/or Services, related costs and/or delivery time, the Seller and the Customer shall agree on the contractual consequences. Should the requirements affect specification and/or performance of the Product and/or Services, related costs and/or delivery time, the Parties shall agree on the contractual consequences.

### 3.3.2 Modifications to Purchase Order modifications by the Customer

Any changes or configuration changes requested by the Customer require prior mutual written agreement of the Parties and may lead to an adjustment of the price and/or delivery time.

---

## 4 - COMPLIANCE, EXPORT CONTROL, CUSTOMS

The Parties hereby undertake to comply at all times with all applicable laws and regulations in particular and not limited to national and international anti-corruption, anti-money laundering and any which impose economic, trade or other restrictive measures, or export, reexport licences or other authorisations in each case issued and enforced by a Sanctions Authority (together "Regulatory Rules").

For the purpose of the Contract,

- "Authorisation(s)" means the approval to export, re-export, transfer or retransfer but not limited to, a governmental licence as may refer to an exemption, an exception, or an agreement issued by the relevant authority under Export Regulations. "Export Regulations" means U.S., E.U. and any other applicable national export control, sanctions and embargoes laws and regulations issued by a Sanctions Authority or export control authority.
- "Sanctions Authority" means the United States of America (including, without limitation, the Department of State, the Department of Commerce and the Office of Foreign Assets Control (OFAC) of the US Department of the Treasury), the United Nations Security Council, the European Union, the United Kingdom or the government of any country with jurisdiction over the Parties.
- "Sanctioned Person" means:

a. any natural or legal person in any list of sanctioned persons of any Sanctions Authority (including the list of Specially Designated Nationals (SDN) and Sectorial or Sanctions Identifications (SSI) list, as issued and administered by OFAC); or

b. any natural or legal person directly or indirectly owned or Controlled by any one or several person(s) designated under (a) above.

## 4.1 Representation from the Customer and Know your Customer policy

The Customer undertakes to provide truthful, accurate and complete information to the Seller such as may be required by the Seller from time to time to comply with its obligations pursuant to the Regulatory Rules, including but not limited to information on the Customer's corporate structure and shareholding, or source of financing of the Contract.

Subject to articles 3.1 and 3.2, the Seller's obligations will only begin once the Seller has received from the Customer all required information and performed all necessary verifications pursuant to the Regulatory Rules and to the "Know your Customer" policy of the Seller. During Contract execution, a) failure by the Customer to comply with the Regulatory Rules and/or b) Customer becomes a Sanctioned Person and/or c) performance of either Party's obligations under the Contract would constitute a breach of Regulatory Rules and/or d) failure by the Customer to timely provide all necessary information and/or cooperate with the Seller, shall entitle the Seller to terminate the Contract forth with without any prior notice and liability whatsoever.

## 4.2 Export control

a) Each Party commits to act in compliance with all applicable Export Regulations. The Customer shall ensure that its supply chain and clients comply with Export Regulations when dealing with the Seller's Items.

b) The Parties acknowledge that performance by the Seller of its obligations under the Contract shall remain subject to obtaining, and to the terms of, any required Authorisation. The Seller shall not be held liable if an Authorisation is not granted or is granted with limited conditions and/or with delay or if an Authorisation that has been granted is amended, suspended, revoked or not renewed. Such event shall be considered as a force majeure event as defined in article 13.

In the event all or part of the Item is subject to import restrictions in the country of the Customer, the Customer shall apply for any relevant import authorisation required for the Seller to perform all or part of the Contract. In addition, the Customer is responsible to obtain the applicable Authorisation for the re-export/re-transfer of any Seller's Item.

Each Party agrees to provide to the other with any declarations or certifications required by Export Regulations and all information necessary to obtain and to comply with any required License (including providing without delay duly completed and signed enduser statement/certificate).

When the Products and Services under the Contract are subject to Authorisations, the Customer undertakes to abide by the content of Authorisations, including specific end-use/end-user and provisions/conditions. Prior to any change in the end-use/end-user or transfer of Item to any third party, the Customer shall notify the Seller thereof and follow the instructions given by the Seller.

c) Should the Customer be involved in ITAR Part 130 or 129, it is the Customer liability to comply with the applicable Export Regulations. The Customer duties is to request for the Seller any applicable declaration as required by the Export Regulations. In the event, the Customer provides to the Seller any USML Items (e.g. return for repair) then the Customer shall complete the corresponding form F provided by the Seller.

d) When the Customer provides any Item to the Seller under the Contract, the Customer shall ensure the required Authorisation is obtained prior to the delivery. In addition, the Customer shall provide in writing to Airbus each Item with all applicable export control classification(s) and the Authorisation number when applicable.

e) The Customer acknowledges that the Seller prior approval is required for the Customer to access any controlled Item and that such access can be granted, refused or revoked at any time by the Seller. To access any controlled Item provided by the Seller, the Customer shall complete and sign the template of compliance declaration for third Party Export Controlled Items access control provided by the Seller.

f) Each Party represents to the other as at the date hereof that neither it nor any of its natural or legal person that has Control over it is a Sanctioned Person. If at any time following the signature of the Contract, a Party or any of its natural or legal person that has Control over it becomes a Sanctioned Person or performance of a Party's obligations under the Contract would constitute a breach of Export Regulations (a "Sanctions Event"), the affected Party shall promptly notify the other Party and the Parties shall, to the extent permitted by applicable Export Regulations, consult with each other with a view to mitigating the effects of such Sanctions Event. Such consultation is without prejudice to the right of either Party to suspend its obligations under the Contract, including to the right of the Seller to deny the access to any digital tool or system when applicable, at any time following the occurrence of a Sanctions Event.

g) The Customer undertakes to use the Item exclusively for civil purpose and that, unless authorised by all applicable Export Regulations, it will not directly or indirectly sell, import, export, reexport, lease, sublease or operate the Item to or in (a) any country which is the subject of commercial, economic or financial restrictions pursuant to any applicable Export Regulations and/or, (b) to any Sanctioned Person.

## 4.3 Customs

If the Customer is in charge of the transportation, in case of intracommunity supply or exportation directly to a country outside the European Union, the Customer will have to provide to the Seller documentation for VAT purposes (proof of transportation and/or import declaration) to justify such intracommunity supply or exportation.

Irrespective of the applicable Incoterm, if Products are exported directly to a country outside the European Union, the Seller will provide appropriate export customs documentation to the Customer or its designated freight forwarder. The Customer guarantees correct closure of the related customs procedure in due time on leaving the European Union or the country of dispatch. In case of non-compliance, the Customer shall be liable for any additional costs and charges imposed on the Seller by the national tax administration.

## 5 - PRICES

### 5.1 General

Prices are stated and payable in Euros.

Helicopter prices and the prices of other Products and Services sold together with Helicopters are according to the baseline Helicopter definition in force at the date of signature of the Contract and to the specific configuration and scope detailed in the Contract.

For Products and Services sold independently of Helicopters, all invoices for Products and Services will be at the prices stated in the relevant Seller's price list in force, or in the relevant Quotation. The Seller's price lists are subject to regular updates.

Prices relate to Products and Services delivered in accordance with the Incoterms mentioned in each Specific Annex of these SCS.

### 5.2 Duties and taxes, VAT

Prices are exclusive of taxes, duties and/or charges resulting from administrative and legislative regulations in force in any country other than the Seller's country and of any customs and duty charges, which shall be borne by the Customer.

Prices are exclusive of VAT or sale taxes or turnover taxes or other similar taxes. If applicable, such taxes will be charged in addition.

### 5.3 Additional costs/ Chargeable amounts

Prices, unless otherwise stipulated in the Contract, do not include any preparation, packing and crating charges nor any modifications carried out at Customer's request before and after delivery, expenses incurred for the inspection of Products by third parties, expenses relating to freight forwarding, carriage by sea, air or land, ferry-flight, storage and insurance costs incurred after Customer's acceptance.

For all Orders below a minimum amount of two hundred (200) Euros, the Seller reserves the right to invoice a minimum amount of two hundred (200) Euros.

## 6 - PAYMENTS

### 6.1 General

The payment obligation will be considered fulfilled at the time the due amount is irrevocably credited in full to the Seller's bank account. The Customer shall make the payment by bank transfer (swift), which, on the Seller's request, may be secured by a stand-by letter of credit or a Documentary Credit.

Subject to article 14.1.2 any down-payments (including intermediate) made before acceptance are non-refundable, as they are necessary to cover the production, procurement, financial, administrative and other costs.

In the event of payment by Documentary Credit, the Customer shall at the time of the initial down-payment and/or Purchase Order, open at its own expense, a Documentary Credit in favour of the Seller for the Contract price, reduced by the initial down-payment, if any. The Documentary Credit shall permit partial deliveries and shall be valid for the total specified period of delivery or performance plus three (3) months covering the time required for preparing the necessary documents and for performing the payment. Should the Documentary Credit expire before full delivery is completed, the Customer shall in due time extend, at its expense, the Documentary Credit without any need for action in this respect on the part of the Seller. The Documentary Credit shall be payable at sight in favour of the Seller as deliveries are made upon presentation of the following documents by the Seller to the bank:

- In case of Helicopter sale :

- Commercial invoice in triplicate,
- Statement of conformity or Certificate of Conformity for Helicopters and optional equipment installed therein,
- Authorized release certificate (EASA Form 1) for packed optional equipment and Spare Parts and
- Certificate of Conformity for miscellaneous parts and tools which are not subject to installation on Helicopter.

- In case of Products and Services sold independently of a Helicopter sale :

- Commercial invoice in duplicate, and
- Any document specified by the Seller and mentioned under the Contract.

As well, the stand-by letter of credit shall be opened at Customer's expense and payable upon presentation by the Seller on first demand to the bank of the here-above described documents.

### 6.2 Payment terms

#### 6.2.1 Sale of Helicopters and associated Services

The Customer shall make the following payments:

- An initial down payment of thirty (30) per cent of the contractual amount no later than fifteen (15) calendar days after the signature of the Contract,

- An intermediate down payment of

- Twenty (20) per cent of the contractual amount, six (6) months prior to delivery for H125, H130, H135 and H145 Helicopters, or
- Thirty (30) per cent of the contractual amount, nine (9) months prior to delivery for H160, H175, H215 and H225 Helicopters,

- The balance of the total contractual amount at the time of the acceptance of the Products and Services and prior to delivery.

In case of sale of pre-owned helicopter(s), the Customer shall make the following payments:

- An initial down payment of thirty (30) per cent of the contractual amount no later than fifteen (15) calendar days after the signature of the Contract,

- The balance of the total contractual amount at the time of the acceptance of the Products and prior to delivery.

#### 6.2.2 Products and Services sold independently of a Helicopter sale

For any Order (except as specified hereinafter), the Customer shall make the following payments:

- Upon Contract signature, a thirty (30) per cent down payment of the total amount of the Contract shall be paid by the Customer no later than fifteen (15) calendar days following the date of invoice;

- Upon delivery of the Products / performance of the Services, the balance of the invoiced amount of the delivered Products or Items / performed Services shall be paid by the Customer no later than thirty (30) calendar days following the date of invoice.

Nevertheless, for Spare Part Orders not exceeding two hundred thousand (200,000) Euros and for R&O Service Orders not exceeding fifty thousand (50,000) Euros, full payment shall be made upon delivery no later than thirty (30) calendar days following the date of invoice.

Payment terms for Services such as, but not limited to, SaaS or Helicopter maintenance, repair, overhaul, upgrade, retrofit or inspection, are specific and defined in the relevant Specific Annex.

Without prejudice to article 6.3, should the Customer be in a situation of past due balance exceedance towards the Seller, the Seller is entitled, without prior notice, to

- alter the terms of payment and request cash in advance payment for any Order and/or

- postpone any Product delivery or Service performance ordered by the Customer to the Seller in any agreement without any liability whatsoever to the Seller; the Seller may charge the Customer for any additional costs and/or expenses incurred as a result of such postponement, such as but not limited to storage, maintenance, loss of training slot.

Unless otherwise agreed, no discount shall be granted by the Seller to the Customer in case of early payment.

## 6.3 Late payment remedies

Payment shall under no circumstances be postponed or apportioned for any reason whatsoever. Consequently, in case of late payment, the Customer shall pay to the Seller interest on the unpaid amount at the rate calculated on the basis of ten (10) percentage points per annum computed on the basis of 365 days/year and the actual number of days elapsed since the due date until the actual date of payment without any need for a formal demand or any prior notice.

Without prejudice to the above, should the Customer fail to pay or in the event of a delay in payment, the Seller will be entitled to extend the schedule for an equivalent time period and/or suspend performance of the Contract and/or in all cases, definitively retain the amount of any payments already made by the Customer. The retention of any such payment shall not preclude the Seller from seeking compensation from the Customer for further damages and/or costs. In the event of a delay or failure by the Customer to pay for more than two (2) months, the Seller shall be entitled to terminate the Contract for default of the Customer under the conditions defined in article 14.1.1.

In addition, when French law is applicable as per article 15, the Customer shall also be liable to the Seller for a fixed amount of forty (40) Euros for cost recovery fees pursuant to French code of commerce article L. 441-6. If the actual costs incurred by the Seller in recovering unpaid sums exceed forty (40) Euros, the Seller shall be entitled to ask for additional compensation upon producing evidence of such actual costs.

---

# 7 - QUALITY ASSURANCE AND AIRWORTHINESS

## 7.1 General

Airbus Helicopters and Airbus Helicopters Deutschland GmbH hold

- a POA issued by EASA according to Part 21/G regulation,

- a maintenance organisation approval in compliance with the EASA Part 145 regulation, as issued by its respective national civil aviation authorities, and

- a training organisation approval in compliance with the EASA Part 147 for maintenance staff and helicopter Part FCL (Flight Crew Licencing) for aircrews as issued by its respective national civil aviation authorities.

The privileges of an approved production organization include the issuance of airworthiness documents.

The Seller holds a CAMO approval certificate issued by its national civil aviation authority in compliance with EASA Part M/ Subpart G.

The official recognition that Products and repaired / overhauled / standard exchange

Items have satisfied the quality assurance procedures is certified by the issuance of the following documents:

For Helicopter(s) in baseline definition and installed optional equipment:

- A Statement of Conformity or Certificate of Conformity issued by the Seller's quality organization to certify compliance with the contractual specification,

- An Aircraft Statement of Conformity (EASA Form 52) for Helicopters sold to customers of EASA member states signed by the Seller's authorized certifying staff within the above mentioned POA. The EASA Form 52 allows the issuance by the national civil aviation authority of the certificate of airworthiness for the European countries members of EASA, or

- A certificate of airworthiness for export, for Helicopters sold outside the European Union, issued by EASA upon submission by the Seller of the above mentioned original Helicopter Statement of Conformity (EASA Form 52),

- For the concerned components/equipment, a logcard,

- Upon request, a certificate of non-registration issued by the national civil aviation authority.

For optional equipment delivered packed, Spare Parts and repaired / overhauled / standard exchange Items:

- Upon request, a Certificate of Conformity or other equivalent document issued by the Seller's authorized certifying staff, for standard components,

- An authorized release certificate (EASA Form 1) for other certified components or non-standard Spare Parts issued on behalf of the national civil aviation authority by the Seller or the Seller's selected workshop,

- A logcard if applicable For new parts/Items: a hard copy or a digital one at the Customer's choice,

For other parts/Items: if the Customer is using the paper format, in the same format as provided by the Customer, the previous customer or previous user as applicable; if the Customer is using the digital format, a digital one,

- A dual or tri release if required through a bi/tri lateral agreement between authorities (e.g. Federal Aviation Regulation (FAR) 145 / Transport Canada Civil Aviation (TCCA) 145).

For miscellaneous parts and tools which are not subject to installation on the Helicopter (if applicable):

- A Certificate of Conformity issued by the Seller's authorized certifying staff.

The Customer that has its civil helicopter registered in a country under EASA regulation is responsible of any task related to the management of the continuing airworthiness of the helicopter or shall transfer this obligation by signing a contract with a CAMO in order to ensure the proper accomplishment of the airworthiness management activities in accordance with the regulations in force (Part M/ Subpart G). Upon signature of the Contract with the Seller, the Customer shall indicate who will assume the responsibility of the CAMO.

## 7.2 Modifications after delivery

The Seller will notify the Customer of any modifications that the competent national airworthiness agency has decided to impose on Helicopters or Spare Parts of the same type. In the event of such modifications, the Seller shall make available to the Customer, within a reasonable time, at the latter's request and expense, the equipment kits required to incorporate such modifications to the Helicopter and Spare Parts previously delivered. For this purpose, the Customer shall receive at no additional cost the technical information bulletins relating to the type of Helicopter mentioned in the Contract for as long as at least one (1) Helicopter of the type remains in service with the Customer.



## 8 - ACCEPTANCE AND TRANSFER OF OWNERSHIP AND RISK

### 8.1 Helicopter acceptance activities

#### 8.1.1 Helicopter acceptance activities by the Seller

Prior to Customer's acceptance activities for new Helicopters, the Seller shall perform production ground and flight tests on Helicopters. Flight tests will not exceed per Helicopter:

- Twenty (20) flight hours for H125, H130, H135 and H145 or,
  - Thirty (30) flight hours for H160 and H175 or,
  - Fifty (50) flight hours for H215 and H225.
- Equipment and components may be delivered with up to fifty (50) hours and/or the remaining time of equipment and components may be reasonably affected by the industrial cycle. Additional hours may be flown in the event that development and installation of specific equipment is requested by the Customer. The cost of such additional hours shall be borne by the Customer. Helicopter non conformities with certified definition, which have an impact on Helicopter operation and maintenance by the Customer, shall be submitted to the Customer for approval.

Upon satisfactory completion of the Seller's acceptance activities, a Certificate of Conformity will be issued by the Seller. As from the date of issuance of this document, the Helicopters shall be deemed ready for Customer's acceptance, referred to as the "Ready for Acceptance" date.

#### 8.1.2 Helicopter acceptance activities by the Customer

Not later than (1) month prior to the date on which a Helicopter is to be Ready for Acceptance by the Customer, the Seller will provide the Customer with a procedure describing the acceptance process (organization, schedule, documents, etc) and document(s) defining the flight tests that could be performed by the Customer (hereinafter referred to as "Acceptance Test Document(s)"). The purpose of these tests is not to re-perform certification tests. These documents shall be valid for all Helicopters of the same type.

Within one (1) week after receipt of the Ready for Acceptance notice, the Customer shall send to the Seller the information required from the Customer's representatives in order to be admitted to the Seller's premises. The Customer's inspection team shall not exceed three (3) persons.

The acceptance activities by the Customer shall not exceed, per Helicopter:

- One (1) day for H125, H130, H135 and H145, or
- Two (2) days for H160, or
- Three (3) days for H175, H215 and H225.

The Customer shall bear its own expenses and costs related to the Customer acceptance activities including but not limited to travel and accommodation of its representatives during this process.

During the Customer's acceptance activities, it may perform acceptance flights, the combined time of which shall not exceed per Helicopter one (1) flight hour for H125, H130, H135 and H145 Helicopters and two (2) flight hours for H160, H175, H215 and H225 Helicopters.

Acceptance flights will follow the format and procedures described in the Acceptance Test Document(s) provided by the Seller and shall be carried out under the responsibility of a Seller's pilot acting as pilot in command.

Unless a major deviation from the specification is found during the Customer's acceptance, the Customer shall accept the Helicopters as being in conformity with the contractual specifications. The acceptance shall be acknowledged by the Customer's signature of an acceptance certificate, designated as "Acceptance Protocol" and/or "Acceptance and Transfer of Ownership Protocol". If the acceptance certificate is not signed within the above acceptance time period, and without such absence of signature being duly justified in writing explaining the precise reason of the rejection and the contractual grounds thereof, or if the Customer does not attend the acceptance procedure, the acceptance shall be deemed to have been granted by the Customer.

### 8.2 Acceptance of Products (other than the Helicopters) and Services

A Certificate of Conformity or equivalent document is issued by the Seller for Products other than the Helicopters.

With regards to Products other than Helicopters, the Customer shall check and notify any defect and/or non-conformity with the Order and/or missing associated documentation in a documented registered letter:

- within twenty one (21) calendar days as from the date the Seller has notified that the Product is ready to be collected, or
- in case of Products delivered CIP or DAP, the time frames for acceptance are the following:
  - forty eight (48) hours for AOG Orders,
  - fifteen (15) calendar days after delivery for Training Items and/or technical publications

and claims against the carrier shall be made within three (3) working days as from the date of receipt of the Product. After expiry of said periods, the Customer's acceptance of the Products shall be deemed given unless the Customer's refusal is duly substantiated in writing and explaining the precise reason of the refusal and the contractual grounds thereof.

For the Services, except SaaS, a certificate of completion of Services or assignment sheet shall be issued once the Service has been performed. The Customer shall sign the form certifying that the Service has been provided in accordance with the Contract. Unless the Customer's refusal is duly substantiated in writing and explains the precise reason of the refusal and the contractual grounds thereof, the Service shall be deemed accepted five (5) working days after issuance of the certificate of completion of the Services or of the assignment sheet. SaaS, including any and all of their supporting elements and content, are provided on an "as is" and "as available" basis.

### 8.3 Collection of Products

After the transfer of ownership, the Customer shall collect the Helicopter within two (2) weeks in case of ferry flight or within one (1) month if it is to be dismantled or conditioned for sea, air or road transport.

If pilot's training has been contractually agreed to take place following the acceptance of the Customer's Helicopter, said duration shall be extended by the time required to train its pilot(s) on its Helicopter.

The Customer shall collect any optional (i.e. not installed on Helicopter) packed equipment, Spare Parts, R&O Items and/or tools:

- within four (4) weeks for Products sold together with Helicopters
- within fifteen (15) calendar days otherwise following the notification by the Seller to the Customer of its availability.

If the Customer fails to pick up its Products within the above mentioned periods of time:

- The Customer shall reimburse the Seller any expenses incurred by the Seller such as maintenance, storage, insurance, taxes and associated penalties if any, levies, etc. The foregoing does not constitute any obligation for the Seller to maintain, store or insure the Products beyond the date the Products should have been collected.
- The Seller may terminate the Contract as per article 14.2 and shall not be liable for any loss or damages incurred by the Customer as a consequence of such termination.

In the event that the Products are delivered in consigned containers, the Customer shall return said containers at its expense within fifteen (15) calendar days after they are made available to the Customer by the freight forwarder. After the expiry of this period, the Seller shall be entitled to invoice the container at its current price.

### 8.4 Transfer of ownership and risk

#### 8.4.1 Helicopters

Transfer of ownership of the Product shall be subject to the prior fulfilment by the Customer of its obligations, in particular full payment of the balance of the Contract and interest, if any. Upon signature of the "Acceptance Protocol" or the "Acceptance and Transfer of Ownership Protocol" by the Seller and the Customer and upon full payment of the Contract price, the ownership of the Products is transferred from the Seller to the Customer. The Seller shall also immediately issue the bill of sale.

All risks relating to the loss of or damage to the Products shall pass to the Customer upon transfer of ownership following delivery, as per the Incoterms specified in the Specific Annex applying to the sale of new Helicopters and associated Services.



Until the transfer of risks to the Customer, the Seller shall maintain an insurance coverage whose the scope, the limits of cover and the duration are as wide as what is usually practiced in the aviation industry for the activities to be performed by the Seller.

From the transfer of ownership to the Customer,

- the Customer shall effect and maintain, at its own cost, an appropriate insurance coverage, including but not limited to a hull all risk and hull war risk insurance coverage;
- with respect to the Customer's hull all risk and hull war risk insurance coverage, the Customer shall cause the insurers of the Customer's hull insurance policies to waive all rights of subrogation against the Seller, its assignees and its directors, officers, agents and employees.

From the transfer of risks, the Customer shall bear all risks related to the Helicopter and waive the right of any recourse of any nature whatsoever against the Seller, its assignees and its directors, officers, agents and employees to this respect.

In case of collection of the Product by the Customer as per article 8.3, the Seller shall remain liable for any damage to the Products due to the Seller's negligence, gross negligence or wilful misconduct until the collection of the Product provided that the collection is made in the timeframe defined in the two first paragraphs of article 8.3.

At Customer's request and costs, and according to the terms of the Contract, the Seller will dismantle and package the Helicopter for transportation after the transfer of ownership.

## 8.4.2 Products other than Helicopters

The transfer of ownership of any Products other than Helicopters shall take place after fulfilment of export customs formalities by the Seller (when applicable):

- at the Seller's facility, at the time of their collection by the forwarding agent appointed by the Customer, or

- in case of Products delivered CIP or DAP, at the mentioned delivery place, and shall be subject to the prior performance by the Customer of its obligations in particular the full payment of the delivered Products and interest, if any.

As a result, should the Customer fail to pay according to the contractual payment terms, the Seller reserves the right to terminate the Contract through notification sent by registered letter and, if the Products are already delivered, to demand that said Products be returned.

As a result, should the Customer fail to pay according to the contractual payment terms, the Seller reserves the right to terminate the Contract through notification sent by registered letter and, if the Products are already delivered, to demand that said Products be returned. If the laws of the country where the Products are delivered do not allow the Seller to regain ownership, the Seller shall be entitled to benefit from any other rights that such laws may confer. The Customer shall implement all measures necessary to protect the Seller's aforementioned rights. In all cases, this will not prevent the Seller from claiming any damages.

Risk of loss or damage to the Products is transferred to the Customer at the time of delivery of the Products by the Seller as determined by the agreed Incoterms® 2020.

## 8.5 Adherence to the delivery date

Adherence to the delivery date is conditioned upon the Customer fulfilling all of its contractual obligations.

## 8.6 Helicopter ownership chain

Without any time limit, the Customer will inform the Seller of any resale of Helicopter(s). This information will be provided in writing and within fifteen (15) days from transfer of ownership to the Customer's buyer and shall include the identity of the new owner and, if available, of the operator.

# 9 - WARRANTY

## 9.1 General

The Seller warrants that the Products and Services provided, except the turbine engine(s),

specific equipment with a STC mentioned in the Contract (if any) and MEGHAS avionics equipment, are free from defects in material and workmanship under normal use and service and that software identified in the applicable Helicopter specification substantially provides the functions set forth in the said specification or in the applicable SB.

The turbine engine(s) as well as the MEGHAS avionics equipment installed in the Helicopter and STCs equipment identified in the Purchase Order are covered by the warranty granted by the manufacturers of these items (Safran Helicopter Engines, Pratt & Whitney and Thales and the STC holder), the benefits of which the Seller hereby assigns on to the Customer who hereby acknowledges and accepts such assignment.

As soon as possible but no later than fifteen (15) calendar days after the discovery of a defect, the Customer shall furnish to the Seller, by using a warranty claim form provided by the Seller, the full details of its claim and the basis thereof. As soon as it receives the said form, the Seller will forward to the Customer a warranty claim acknowledgment and a RMA form. Within fifteen (15) calendar days following the receipt of such documents the Customer shall return the allegedly defective Parts to the Seller. If the Customer fails to return the allegedly defective Parts in due time, the Seller reserves the right to invoice the replacement Parts which have been ordered or produced for the Customer at the price stated in the relevant Seller's price list in force, or in the relevant Quotation.

The Seller will compensate reasonable transportation costs outbound from the Customer premises to the Seller's premises for the repairable Parts for which the benefit of the warranty has been granted by the Seller. The Customer shall send the invoice to the Seller by the end of each quarter and in any case not later than three (3) months after the acceptance by the Seller of the warranty claim. Corresponding credit notification will be issued on a quarterly basis by the Seller and shall be applicable to Spare Parts and/or R&O invoice(s). Insurance, customs expenses and other charges as well as the expenses incurred by the Customer for the removal, re-installation, calibration and troubleshooting operations with respect to such Parts shall be borne by the Customer.

However, during the first year of the warranty of a new civil Helicopter (except H215 one), for each valid warranty claim, the Seller will compensate in kind the Customer for reasonable labour charges related to warranty issues on the basis of removal and re-installation of the concerned Part(s) (troubleshooting excluded). These labour charges flat rates in force are defined by the Seller per category and are available to the Customer on request. Such compensation shall be cumulated on a monthly basis under the form of a credit which shall be valid for one (1) year and shall be used by the Customers for paying ordered Spare Parts. If applicable, the Customer hereby authorizes the Seller to grant the credit to the company who manages and performs the warranty claim on its behalf for the final benefit of the said Customer.

Said credit(s) shall not apply in case of Customer's default, such as, but not limited to, late payment and payment failure.

For Parts for which the benefit of the warranty has been granted by the Seller, the return transportation costs to the Customer premises shall be borne by the Seller.

The warranty exclusions are as follows:

- in the event that maintenance activities have not been properly entered in the appropriate logbook (or in case of failure to produce the logbook to the Seller if so requested), or

- in the event of a defect that is the result of normal wear and tear, or

- Parts and any associated costs incurred for scheduled maintenance, or

- if the Parts have been stored, protected, freighted, operated, maintained, installed, altered, repaired or overhauled otherwise than in accordance with the manuals, documentation and instructions delivered by the Seller or its subcontractors/suppliers, or

- if the Parts has suffered an accident, or

- if a defect of the Part(s) alleged by the Customer is not confirmed during the technical expertise done by the Seller, or

- if the Parts have not been delivered by the Seller, or

- if the defect is partly or wholly caused by a defective item not provided by the Seller, or

- if the software or the host media is exposed to any computer virus or to any conditions in excess of those published in the applicable manuals, documentation and instructions delivered by the Seller, as well as any alteration and/or modification not validated by the Seller, having an impact on the software, or

normal wear and tear of item(s) such as, but not limited to, seals, tires, inner tubes, bulbs, packings and similar consumables parts.

The warranty is granted to the Customer personally. As a consequence, should the Customer sell a Helicopter during the warranty period, it undertakes to notify the Seller of the new owner's name at the time of the transfer of title. Notwithstanding, any request for warranty transfer to any third party within the six (6) months following the Helicopter's delivery is subject to the prior written consent of the Seller. Should the Customer want the warranty to be managed by a third party, it shall then provide the Seller with a power of attorney authorizing the said third party to act on its behalf. The warranty constitutes the Seller's sole liability in case of breach of the warranty obligation, and is exclusive and in lieu of any other warranty or remedy available under the Contract or at law (to the extent permitted at law).

## 9.2 Warranty period

The Seller's obligation under the warranty is limited to the repair - or replacement at the Seller's discretion - of the allegedly defective Products or Services that have been returned to its facility and, at the time of any repair or replacement have been recognized by the Seller after expert investigation as defective. To be eligible under this warranty, the alleged failure must have occurred within the time-limits mentioned here-after:

- For new civil Helicopter(s) in baseline definition and installed optional equipment:
  - Within two thousand (2,000) flying hours or thirty six (36) months after their acceptance at the Seller's factory, whichever event occurs first.
- For Spare Part(s) and SB kit(s):
  - Within one thousand (1,000) flying hours or twelve (12) months from the time they are fitted to the Helicopters or twenty four (24) months after their delivery from the Seller's factory, whichever event occurs first.
- For tool(s):
  - Within twenty four (24) months after their delivery from the Seller's factory.
- For Training Item(s):
  - Within the twelve (12) months after their delivery from the Seller's factory.
- For repaired, overhauled and standard exchange Items, and used Part(s):
  - Within five hundred (500) flying hours or six (6) months from the time they are fitted to the Helicopters or twelve (12) months after their delivery from the Seller's site, whichever event occurs first. For repaired Item, the warranty is limited to the repair done and/or the Parts replaced.
- For tools repaired, overhauled or returned for calibration:
  - Within twelve (12) months after their delivery from the Seller's site.
- For workmanship:
  - Within five hundred (500) flying hours or six (6) months from the signature date of the acceptance certificate by both Parties, whichever event occurs first.
- Warranty periods in case of sale of pre-owned Helicopter(s) are defined in the relevant Specific Annex.

Software identified in the applicable Helicopter specification shall only be considered as non-conforming, if there are substantial deviations of the functions supported by software from the Helicopter specifications. The Seller will, at its sole discretion, remedy such non-conforming software for the considered Helicopter by providing a correction release of the software or by finding a reasonable workaround. The Customer shall supply the Seller with all necessary information and documentation in its possession, to enable the Seller to investigate and rectify such non-conforming software. The Seller warrants the software identified in the applicable Helicopter specification provided that the alleged warranty is notified by the Customer to the Seller within one hundred and eighty (180) calendar days from the date of delivery of the Helicopter to the Customer.

The warranty conditions for software embedded in the delivered Spare Parts or in the delivered repaired/overhauled/ standard exchange Item shall be the ones applicable to the software delivered with the Helicopter, as mentioned in the previous paragraph.

Any SaaS, including any and all of their supporting elements and content, are provided "as is" and "as available". The warranty period on the repaired or replaced part(s) shall be the warranty period that was remaining on the respective defective part. The part(s) removed for which the Seller supplies a replacement part(s) shall become the property of the Seller.

## 9-3 German legal warranty

For Contracts governed by German law, the German legal warranty (Sachmängelhaftung) supersedes the standard warranty conditions described here above for the first twelve (12) months. During this period, and provided that the German legal warranty is applicable, the Seller may elect to repair or replace the defective Products.

## 10 - CONFIDENTIALITY

During the performance of the Contract, the proprietary information of the Parties shall be protected as follows: the term "Proprietary Information" shall mean any information or data in whatever form (either in writing or orally, subject to the conditions set forth hereinafter, and including but not limited to any written or printed documents, samples, models or any means of disclosing such Proprietary Information that the disclosing Party may elect to use during the life of the Contract), disclosed by either Party to the other and which is designated as proprietary to the disclosing Party by an appropriate stamp, legend or any other notice in writing, or when disclosed orally, has been identified as proprietary at the time of disclosure and has been promptly (thirty (30) calendar days at the latest) confirmed and designated in writing as Proprietary Information of the disclosing Party.

The receiving Party hereby covenants that, from the effective date of the Contract, the Proprietary Information received from the disclosing Party shall:

- a) be protected and kept in strict confidence by the receiving Party, which must use the same degree of precaution and safeguards as it uses to protect its own Proprietary Information of like importance, but in no case any less than reasonable care; and
- b) be only disclosed to and used by those persons within the receiving Party's organization (including temporary workers) and its Affiliates, external counsels, lawyers, accountants, auditors, banks, insurers and IT Service Providers, who have a need to know and solely for the purpose specified in the Contract (and provided such entities are bound by confidentiality obligations either at least as constraining or resulting from a professional duty by operation of law); and c) not be used, in whole or in part, for any purpose other than the purpose of the Contract without the prior written consent of the disclosing Party; and
- d) neither be disclosed nor caused to be disclosed, whether directly or indirectly to any third party or persons other than those mentioned in subparagraph b) above; and
- e) neither be copied nor otherwise reproduced nor duplicated, in whole or in part, where such copying, reproduction or duplication has not been specifically authorized in writing by the disclosing Party.

Any Proprietary Information and copies thereof disclosed by either Party to the other shall, subject to any third party rights, remain the property of the disclosing Party and shall be immediately returned by the receiving Party upon request.

Notwithstanding the confidentiality obligations stated in the Contract, the receiving Party may disclose the Proprietary Information to any governmental agency or judge legally authorized to have mandatory access to such information, provided however that in these circumstances, the receiving Party shall prior to disclosure notify the disclosing Party to give the disclosing Party the opportunity to take appropriate action(s), as far as available, against such disclosure.

AH, as a French company, is under the obligation to comply with French Law n°68-678 (as modified by Law n°80-538) regarding the communication of documents and information of economic, commercial, industrial, financial or technical nature to natural or legal entities abroad.

## 11 - INTELLECTUAL PROPERTY

AH and/or AHD retain all rights in respect of developments, inventions, know-how, production procedures and any intellectual property rights relating to the Products that they manufacture and/or Services related thereto.

Nothing in the SCS shall be construed as a legal transfer of or licence to (other than specified hereafter), any patent, utility or design model, copyright, trademark, know-how or other intellectual property right. Copying and/or reproducing and/or communication and/or transmission to a third party of Seller's Products or Services or technical information or publications or training manuals, either wholly or partially, without the Seller's written express approval is strictly forbidden (except for the copying by the Customer of technical documentation provided by the Seller exclusively for the purposes of operation and maintenance of the Helicopters by the Customer).

The Seller grants the Customer a non-exclusive, non-transferable licence to use

- a SaaS for the purposes of operating and/or maintaining helicopters and/or
- the executable form of the software on the related Product, for the purposes of operating the Helicopters.

This licence does not entitle the Customer to receive free of charge updates of such software. The Customer shall not decompile, disassemble, modify, reverse assemble, reverse engineer or reduce to human readable form, the software and/or any SaaS except to the extent the foregoing restriction is, by operation of applicable law, prohibited or of no effect.

---

## 12 - LIABILITY

Notwithstanding any provision to the contrary in the Contract or elsewhere, the total and cumulated liability of the Seller under the Contract, due to any and all causes whatsoever, whether based on breach of contract or in tort or otherwise, shall in no event exceed in aggregate an amount equivalent to ten per cent (10%) of the total net Contract price (excluding taxes) or in case a specific Order is passed and the triggering event of liability relates to that Order, ten per cent (10%) of the total net Order price (excluding taxes).

The above limitation shall not apply in the event of gross negligence, wilful misconduct, death or bodily injury.

Each Party shall be responsible for death or bodily injury arising to its own personnel, whatever the cause. The Parties therefore waive the right to any claim against the other in this respect, except if such death or bodily injury is caused by the gross negligence or wilful misconduct of the other Party.

In no event shall the Parties be liable for any indirect, consequential, incidental, special or punitive damages of any kind, including, but not limited to, damages for any loss of use or profit, loss of assets, loss resulting from business disruption, loss of goodwill or loss of contractual opportunity by the other Party.

To the extent permitted at law, the Seller's obligations and liabilities and the Customer's rights and remedies as set forth in the Contract are exclusive and are in replacement of any and all other remedies under law or otherwise.

---

## 13 - FORCE MAJEURE AND EXCUSABLE DELAY

### 13.1 Force majeure

The Seller shall not be held responsible for failure to perform or delay in performing any of the contractual obligations of the Contract if such failure or delay is due to, but not limited to:

- acts of God, war, insurrection, epidemics, sabotage, labour disputes, strikes, lock-outs, shortages of labour, interruption or delays in transportation, fire, explosion, equipment or machinery breakdown, failure or delays of the Seller's sources of supply, shortage in material or energy, or
- acts, orders or priorities resulting from any government action, national or international authorities, or
- acts caused by any supplier or subcontractor of the Seller (or lower level subcontractor or supplier), or
- a bankruptcy or insolvency event concerning any supplier or subcontractor (or lower level subcontractor or supplier), or
- any other case beyond the reasonable control of the Seller.

For the avoidance of doubt, the delay or absence of payment by the Customer cannot be considered by it as a case of force majeure.

In case of force majeure, the contractual delivery date shall be extended by such period of time reasonably required to remove and/or overcome the event of force majeure and its effects.

### 13.2 Excusable delay

Any postponement of the contractual dates due to the following causes shall not constitute a delay:

- a) BFE/CFE not delivered according to the schedule stated in the Contract or found defective and which consequently requires to be replaced by the Customer or,
- b) Changes or additions to the Contract requested by the Customer or,
- c) Any failure or omission by the Customer to perform its obligations set forth in the Contract.

Any additional costs incurred by the Seller as a result of the occurrence of one of the above events shall be invoiced by the Seller and paid by the Customer over and above the Contract Price.

---

## 14 - TERMINATION

### 14.1 Termination for default

A Party may terminate all or part of the Contract for default of the other Party in the event that the other Party persistently fails to perform its obligations and despite the non-defaulting Party having notified by acknowledgment of receipt the defaulting Party to take adequate corrective measures and provided no such measures have been proven to have been taken within a period of two (2) months, following the above notice. The termination shall occur without any specific formality other than the above notice.

In the case of termination for default, the following shall apply:

#### 14.1.1 In case of default of the Customer:

a) the Customer shall indemnify the Seller for all costs and damages (including but not limited to raw materials, labour, overhead, storage fees, work in progress) incurred by the Seller or which the Seller could not avoid incurring (including termination indemnities, if any, under the contracts between the Seller and its subcontractors or suppliers or under the second level contracts or subcontracts),

b) the Customer shall pay to the Seller a termination indemnity equal to ten per cent (10%) of the contractual price as well as an indemnity equal to the damages sustained by the Seller,

c) the Customer shall indemnify the Seller in case other remedies are available by the Customer under the Contract, than those mentioned under paragraphs a) to b) above, and

d) the Seller shall be entitled to retain any payments already made by the Customer, until an agreement is found on the above or the dispute resolution has been implemented and a decision has been taken in consequence.

#### 14.1.2 In case of default of the Seller:

a) the Seller shall be entitled to deliver the remaining non-faulty Products and render the remaining non-faulty Services, and shall be paid the corresponding price thereof, and

b) the Seller shall return to the Customer all the BFE/CFE remaining in its premises, once the Products are delivered and/or the Services are rendered, and

c) the Seller shall refund the Customer, the amount of the down payment which refers to the unfulfilled part of the Contract.

### 14.2 Termination for force majeure

In case of the occurrence of a force majeure event as provided in article 13.1 results in the contractual delivery or performance dates being extended by more than six (6) consecutive months, the Parties shall meet in order to determine under which conditions they wish to pursue the Contract or if they do not reach an agreement within a one (1) month period, either Party shall be entitled to terminate the Contract, without being entitled to claim for any damages or compensation in any form whatsoever.

## 15 - APPLICABLE LAW AND DISPUTE RESOLUTION

The Contract shall be governed by German law for the sale of Products and/or Services by Airbus Helicopters Deutschland GmbH and by French law for the sale of Products and/or Services by Airbus Helicopters. Irrespective of the applicable law, the United Nations Convention for the international sale of goods is excluded.

The Parties shall attempt to amicably settle any dispute, controversy or claim arising out of or in connection with the Contract, including through mediation (under the authority of a neutral, independent mediator to be jointly appointed by the Parties). If two (2) months after the occurrence of such dispute, controversy or claim, the Parties have failed to reach an agreement (unless they agree to extend the amicable phase), then the dispute, controversy or claim shall be settled as follows, depending on the contractual aggregate amount:

- A dispute will be finally settled under the rules of arbitration of the International Chamber of Commerce (ICC) by three (3) arbitrators appointed in accordance with the said rules.

- In the specific case of a dispute of which the aggregate amount does not exceed ten million (10 000 000) Euros, the Parties agree to opt for a fast track arbitration process in accordance with the ICC rules.

The place of arbitration shall be Geneva (Switzerland) and the language of the arbitration shall be English.

However, in all cases, should the Seller elect to choose a local court jurisdiction due to arbitration not being adapted to the specific nature of the dispute, in particular the need for immediate injunctive relief or to recover sums due, then such local court will be competent to settle the dispute.

The Parties hereby consent and agree to be subject to the jurisdiction of the aforesaid courts and/or arbitration and, to the greatest extent permitted by the applicable law, the Parties hereby waive any right to seek to avoid the jurisdiction of the above courts on the basis of the doctrine of forum non conveniens.

Unless otherwise agreed by both Parties, the fact that any dispute has been referred to arbitration pursuant to this article shall not relieve either Party from any of its obligations as set out in the Contract.

## 16 - DATA EXCHANGE

### 16.1 General

In order to improve the Products, their reliability and availability and the Customer services, the Seller has set up a data exchange process based on maintenance and operational data coming from the Customer's helicopters in service. The Data will notably consist of:

- Helicopter data generated by on-board recording systems,
- information system data, such as maintenance, operation, logistics and airworthiness data and
- data loaded to, transmitted by and/or stored as well as data generated by the SaaS as a result of the use of the SaaS.

For these purposes, the Customer, or its designated entity for operations and/or maintenance, hereby authorizes the Seller on a free and non-exclusively basis:

- to collect such Data.
- to use the Data to create processed data (data which is reconciled, enriched, qualified and analysed by AH) (hereinafter the "Processed data"),
- to anonymize such Processed data (Processed data which is anonymized, not enabling to identify the Customer) (hereinafter the "Anonymous data"),
- to disclose Data, Anonymous data and Processed data internally only to those of its employees (for the avoidance of doubt, this shall include temporary agency workers and freelancers) and/or Customer Centres having a need to have access to such data for the purpose (\*) stated below,
- to disclose Data and Processed Data to partners, suppliers and/or subcontractors of AH (i) having a need to have access to such data for the purpose (\*) stated below and (ii) being bound by confidentiality obligations,

- to disclose Anonymous data to partners, suppliers and/or subcontractors of the AH for the purpose (\*) stated below,

- to use and disclose to customers Anonymous data (including after being complemented with additional sources of anonymous data) for the purpose (\*\*) stated below, and

- to store Data, Processed data and Anonymous data.

(\*) Disclosure shall be for the purpose of further software & service development, helicopter improvement & expert analysis.

(\*\*) Trend monitoring, benchmarking services, report issuance, analyses and customer workshops for helicopter maturity.

Data, Anonymous data and Processed data may also be used for the purposes of supporting the Customer subject to a specific agreement.

### 16.2 Data confidentiality and intellectual property

The Parties agree that any and all Data disclosed by the Customer or its designated entity to AH shall be deemed confidential. Nevertheless, AH shall be entitled to disclose Data and Processed data to the persons and entities and at the conditions described under article 16.1 above. Anonymous data (including after being complemented with additional sources of anonymous data) can however be used and disclosed by the Seller without being subject to any confidentiality limitations/obligations.

AH owns all foreground intellectual property and know-how, if any, generated by the outcome of the analysis of the Data, Processed data and/or Anonymous data.

### 16.3 Data related liability

Notwithstanding anything to the contrary in the Contract, the Seller or its Customer Centers shall not be liable toward the Customer or its designated entity in the frame of the analysis of the Data and/or in connection with the Customer's helicopter maintenance, repair and flight operations as a result of the disclosure of confidential information by the Customer or its designated entity to the Seller or its Customer Centers or as the result of any exchange or analysis of information collected through the process.

## 17 - MISCELLANEOUS

These SCS along with the applicable Specific Annex(es) and Purchase Order (or Order) constitute the entire agreement between the Seller and the Customer. They supersede all previous communications and/or agreements either oral or written, between the Seller and the Customer with respect to the Products or Services.

In the event that one (1) or more of the articles provided for in these SCS is deemed invalid or unenforceable, the remaining provisions shall remain entirely valid and applicable.

English shall be the language of the Contract. Both Parties shall use English as the language to exchange, issue and deliver information, documentation and notices, and any related documents excluding those documents which might be produced by a governmental institution in the local language.

In the Contract, unless the contrary intention appears:

- headings are for the purpose of convenient reference only and do not form part of the Contract;

- where the last day of any period prescribed for the doing of an action falls on a day which is not a working day in the country of the applicable law, the action shall be done no later than the end of the next working day.

In case of any contradictions and discrepancies between the parts of the Contract, precedence shall be given in the following decreasing order:

- 1) Purchase Order, Order or Order Confirmation (as applicable)
- 2) Present SCS
- 3) Specific Annex(es)
- 4) Other Annexes and/or appendices in their order of appearance.

The provisions of the confidentiality, intellectual property, liability, applicable law and dispute resolution articles of the Contract shall survive and continue to have effect after the termination or expiry for any reason whatsoever of the Contract, and for a period of thirty (30) years thereafter.

No term or provision hereof will be considered waived by either Party, and no breach excused by either Party, unless such waiver or consent is in writing and signed by the Party against whom the waiver is asserted. No consent by either Party to, or waiver of, a breach by either Party, whether express or implied, will constitute a consent to, waiver of, or excuse of any other, different or subsequent breach by either Party.

Any variation or modification of the Contract shall be made in writing through an amendment and signed by duly authorised representatives of each Party.

The relationship between the Seller and the Customer is solely that of purchaser and seller. No joint venture or partnership is intended nor will any be construed from the Contract. Neither Party will have the authority to enter into contracts on behalf of or bind the other in any respect.

The Customer shall not be entitled, without the prior written consent of the Seller, to assign or transfer to a third party all or part of the rights and obligations under the Contract.



# STANDARD CONDITIONS OF SALE SPECIFIC ANNEX APPLYING TO THE SALE OF SPARE PARTS

## B1 - GENERAL

This Specific Annex, subject to SCS, is applicable to sale of Spare Parts, including tools, SB kits and STCs performed by the Seller to any Customer in order to maintain and/or operate Helicopters.

## B2 - DELIVERY AND INCOTERMS

Unless the Contract stipulates another Incoterm, Spare Parts shall be delivered packed Free Carrier (FCA) Incoterms® 2020 at the Seller's site or logistic platform as specified in the Purchase Order.

In case of unavailability of the Spare Parts or of raw material, the Seller shall be entitled to make partial deliveries.

## B3 - ORDER'S TYPOLOGY AND SPECIFICITIES

### B3-1 Planned Purchase Orders

Purchase Orders of Spare Parts shall be considered as planned Purchased Orders if the requested delivery date is above two (2) weeks from the date of receipt by the Seller of a valid Customer's Order (Order Date), under FCA Incoterms® 2020 defined in Article B2. In case of complete or partial modification of the Order, the date of receipt shall be updated accordingly.

For each Order line of any planned and confirmed Purchased Orders, the Seller shall commit on delivery performance, except for critical part(s) as mentioned in the Order Confirmation. In case of late delivery, the Seller will grant to the Customer a credit under the conditions defined hereafter:

- If the Spare Part(s) ordered is(are) "on collection" as identified in the Seller's price list in force and is(are) delivered by the Seller after the delivery date requested by the Customer, the credit per delayed Spare Part shall depend on the timeframe between the requested delivery date and the Order Date, under FCA Incoterms® 2020 defined in Article B2, as follows:
  - Timeframe of fifteen (15) calendar days up to thirty (30) calendar days: eight (8) per cent of the invoiced value of the Spare Part; the total credit per Order's line shall not exceed four thousand (4 000) euros;
  - Timeframe of thirty one (31) calendar days up to sixty (60) calendar days: twelve (12) per cent of the invoiced value of the Spare Part; the total credit per Order's line shall not exceed six thousand (6 000) euros;
  - Timeframe of more than sixty (60) calendar days: sixteen (16) per cent of the invoiced value of the Spare Part; the total credit per Order's line shall not exceed eight thousand (8 000) euros.
- If the Spare Part(s) ordered is(are) "on demand" as identified in the Seller's price list in force, the Seller shall propose a delivery date and commit on it in the Order Confirmation. If the Seller delivers the Spare Part(s) on demand after the said committed delivery date, the credit per delayed Spare Part shall equal to sixteen (16) per cent of the invoiced value of the Spare part; the total credit per Order's line shall not exceed eight thousand (8 000) euros.
- The credit shall not apply in case of an event disrupting the logistic flow for reasons not attributable to the Seller.
- The eligible credits shall be cumulated from 1st of January to 31st December of year n and the related total amount will be then granted under the form of a credit which shall be valid from 1st of April until 31st December of year n+1 and shall be used by the Customers for paying ordered Spare Parts. Said credit shall not apply in case of Customer's default, such as, but not limited to, late payment and payment default.

If the Contract stipulates another Incoterm than FCA Incoterms® 2020, the conditions for

allocating the credit are subject to adjustments and shall be agreed between the Parties.

### B3-2 Rush Purchase Orders

The Rush Purchase Order is an Order with a requested delivery time below two (2) weeks from the date of its receipt by the Seller, the Customer not being in AOG situation.

### B3-3 AOG Purchase Orders

To guarantee an efficient service to the Customer and respond quickly to any situation where the Customer's Helicopter is AOG, the Seller provides a twenty four (24) hours a day/seven (7) days a week AOG service. The AOG service is available for Orders of Spare Parts which are essential to put a Helicopter back into service or to enable it to perform its mission.

Any Spare Parts listed in the Seller's illustrated Parts catalog can be ordered by the Customer via AOG service, except main assemblies, raw materials, ingredients and hazardous materials.

The AOG service is provided to the Customer at the price stated in the relevant Seller's price list in force or in the relevant Quotation plus a surcharge fee of three hundred (300) euros (excluding transportation) charged per confirmed AOG Order. A flat rate for transportation cost will be added to the price of Spare Parts.

The Customer shall also mention in writing regarding any AOG Order placed to the Seller, the following information:

- Part number/ nomenclature
- Failure description and reason of removal
- Quantity required for the specific AOG
- Ship to address

The Seller, by sending an Order Confirmation, shall confirm in writing to the Customer the price and the delivery time within twelve (12) hours after receipt of the Customer's Order.

The Spare Parts already available in the Seller's inventory upon receiving the Order from the Customer will be delivered packed Carriage Insurance Paid (CIP) Incoterms® 2020 to the nearest international airport to the Customer and within seventy two (72) hours after receipt by the Seller of the Customer's Order, depending on the delivery location.

The Customer may order in AOG the concerned Spare Parts in accordance with the quantity fitted on the Helicopter. If several line items are ordered, the Seller has the right to make partial deliveries, depending on the availability of the Spare Parts.

The Customer shall check the Spare Parts provided in AOG conditions, notify any recognisable defects in a documented registered letter within forty eight (48) hours as from the date the Spare Parts have been received by the Customer and place them at Seller's disposal.

## B4 - SB kit and STC

Unless otherwise specified, the kits originated from SB or STC modification are defined on the basis of the "as-delivered" configuration (i.e. the configuration of the Helicopter at the time of transfer of title from the Seller to the original customer). It is the responsibility of the Customer to make sure that the actual configuration of the Helicopter corresponds to the pre-mod configuration of the relevant SB or STC installation instruction. Any deviation of the actual configuration that requires the amendment of the SB or the STC installation instruction shall be charged to the Customer on a time and material basis.

Unless otherwise specified, the STC is sold to the Customer with the certification(s) as listed in the catalog and specified in the offer. It is the responsibility of the Customer to make sure that such certification(s) are acceptable to its competent airworthiness authority before the installation of the kit. The Seller will provide all reasonable support to the Customer for the additional certification or validation of the existing certification(s) at the latter's sole expense on a time and material basis.

The STC holder of the Product shall retain full responsibility for the type design definition its own Product (configuration, definition, necessary changes and continuing airworthiness). The Seller does not warrant the compatibility of the STC with future mandatory or non-mandatory modifications.





## Contacts

Please contact your usual AIRBUS HELICOPTERS commercial interface

# AIRBUS

### © Airbus

Aéroport International Marseille Provence  
13725 Marignane Cedex - France  
©Airbus 2023 - All rights reserved. Airbus,  
its logo and product names are registered  
trademarks.

Airbus Helicopters reserves the right to  
make configuration and data changes at  
any time without notice. The facts and  
figures contained in this document and  
expressed in good faith do not constitute  
any offer or contract with Airbus  
Helicopters.

Concept design by Kaiman  
Photos by DR - © Airbus Helicopters

Standard Upgrades 2023